

THE COMPUTER JOURNAL[®]

For Those Who Interface, Build, and Apply Micros

Vol. II, No. 1

\$2.50 US

Part Two:

Optoelectronics page 2

Multi-user page 11

True RMS Measurements page 12

Gemini—10X;
Modifications to Allow
Both Serial and Parallel Operation page 16

Regular Features:

Books of Interest page 18

New Products page 20

Editor's Page

Choosing A System

Most of us are not faced with the decision of choosing a system for real world applications when we first start working in this field because we just drift into using whatever equipment is available to us. Eventually we need a different (or an additional) system, or someone asks our advice on setting up a system. At this time we have to either determine what equipment is best suited for this application, or take the easy way out and just duplicate what we are currently using.

It is human nature to remain loyal to a product with which we are familiar and which has given us good service in other applications, but a computer system that is great for word processing or spread sheets may not be a good choice for measurement and control. Of course, the opposite is also true, a system which is good for measurement and control may be useless for general office work.

The first step in selecting a computer for any application is to decide what functions the system will have to perform, and how much money is available (it is never enough). Then comes the challenge of locating equipment that will meet the functional requirements without exceeding the funds available for the project. For most of us, the cost is a primary consideration when choosing a system.

We have recently acquired an additional system to supplement the Apple II. We have been using the Apple for word processing, maintaining the mailing list database, and running the phototypesetter. The first decision was whether the second system should be another Apple or an entirely different system. Some of the things we considered were: 1) Languages available, 2) Utility programs available, 3) Ability to add wide range of Input/output ports, 4) Disk storage, 5) Capability of future expansion, and 6) System cost.

Languages—The Apple comes with Basic and there are several good assemblers available, but we were not happy with the implementation of some of the other languages, and were not sure about the availability of Cbasic or C. These languages plus most others commonly used on micros are widely available for CP/M and there is usually a choice of different features from various vendors.

Utility Programs—The two systems with the widest variety of utility programs are the Apple and CP/M. We were not interested in fancy word processors, spreadsheets, data bases, graphics, mice, integrated programs, windows, or any of the other current fads; but rather a powerful 'open' operating system, assemblers, compilers, stepper motor controllers, linear optimization, computer aided drafting, A/D and D/A, circuit design, etc.

I/O Ports—While it is possible to add I/O to even the simplest micros such as the Sinclair, many of the current

micros are really not intended to interface to anything other than a printer. Multiple ports are desirable when interfacing the numerous motors and sensors in a robotic device or in N/C machining, and we felt that the two systems with the most flexible I/O capability are the Apple and the S-100 system operating under CP/M.

Disk Storage—We wanted to be able to use double sided double density eight inch disks with a capacity of 1.2 megabytes on a removable media, be able to read and write various 5¼ inch disk formats for exchanging data with others, and the ability to add a hard disk in the future. The S-100 system is the only one we located which can do this easily with off-the-shelf components.

Capability of future expansion—The Apple shows continued growth in our area of interest, but some of the enhancements (such as an 80 column card) are expensive and do not always work with all software. We would like to upgrade to a 16 bit system, and while 16 bit cards are available for the Apple we feel that as long as we are getting another system it would be better to start with something else rather than to buy an Apple with the intention of upgrading it to 16 bits. The IBM PC is interesting, but we do not agree with their choice of CPU and most of the software is business oriented rather than control oriented. The S-100 system is very flexible for development or evaluation work as cards with Z-80, 8086, 68000, and other CPU's are available. There are also 8087 math processor cards, graphics cards, multi-user and multiprocessor systems and much more available for the S-100 system.

continued on page 15

*Editor/Publisher..... Art Carlson
Art Director..... Joan Thompson
Technical Editor..... Lance Rose
Technical Editor..... Phil Wells
Production Assistant..... Judie Overbeek
Contributing Editor..... Ernie Brooner*

The Computer Journal® is published 12 times a year. Annual subscription is \$24 in the U.S., \$30 in Canada, and \$39 in other countries.

Entire contents copyright © 1984 by The Computer Journal.

Postmaster: Send address changes to: The Computer Journal, P.O. Box 1697, Kalispell, MT 59903-1697.

Address all editorial, advertising and subscription inquiries to: The Computer Journal, P.O. Box 1697, Kalispell, MT 59903-1697.

OPTOELECTRONICS, Part Two

by Roger Johnson

Previously we discussed how light is generated, detected, and quantified. Some circuitry using LEDs and LCDs were shown as well as techniques needed to drive the particular display. Now let's take a look at how optoelectronics detects and uses light in a practical way.

The four most common detectors of light are the cadmium sulphide (CdS) cell, the solar cell, the photodiode, and the phototransistor. All of these devices are wavelength selective depending on the manufacturing materials and methods used in their fabrication.

The CdS cell is a two lead device whose resistance changes with incident light intensity. Bright light gives a few hundred ohms and darkness represents a few megohms. Figure 1 shows some applications using the CdS cell. Its main disadvantages in opto work are its low sensitivity, non-linear output, and slow response time. It is also very temperature sensitive.

Figure 2 shows the schematic symbol for a solar cell, a battery symbol with the Greek letter "lambda" indicating light input. These are used mainly in providing electricity from sunlight. There are two figures of merit for solar cells: conversion efficiency and cost per watt. Today the best conversion efficiencies are about 10%. That compares to about 20% for the internal combustion engine. In commercial quantities the cost is about \$10 per watt, a very high figure.

Figure 2 also shows a solar powered battery back-up and trickle charger circuit. When the voltage from the cells drops below about 9.7 volts, then D1 becomes reverse biased and the battery takes over by conduction through now forward biased D2. With sunlight on the cells, the battery is trickle charged constantly through the 100 ohm resistor. These cells will produce 0.2 amps of current at a regulated

output voltage of 5 volts at a cost of \$50 per watt. This compares to about \$2 per watt cost of a normal line operated power supply. However, when the cost warrants it, solar is a good choice.

Figure 3 shows the phototransistor. Light striking the base region creates electron-hole pairs which causes and controls the collector current. Some devices have a separate base lead for establishing a quiescent base current. Phototransistors produce more current than photodiodes but at the expense of speed. Typical values are a few milliamps of collector current for incident power levels of a half milliwatt or so. Rise and fall times are about 10 microseconds.

In both phototransistors and photodiodes, a current flows in the absence of any light. This is called dark or leakage current and will always set the ultimate detectivity of a system. This current is the result of random, thermal collisions of electrons with bulk silicon in the base or depletion region. Practically, you'll always want to design your optoelectronics to be detector noise limited as opposed to amplifier noise limited. More on this later.

As Figure 3 shows, all that is needed for a phototransistor to operate is a collector resistor. Be sure not to exceed the Vce rating for your phototransistor. Typical collector-to-emitter "never exceed" voltages are around 30 volts. Let's say that a 1 mcd LED produces 0.2 ma of collector current when it is 2.5 cm (1 inch) away. The collector resistor should be:

$$R = (5 - 0.4)/0.2\text{ma} = 23\text{K}$$

What if we wanted to drive a TTL gate with this? We can't, since a TTL input requires 1.6 ma of sinking current at 0.4

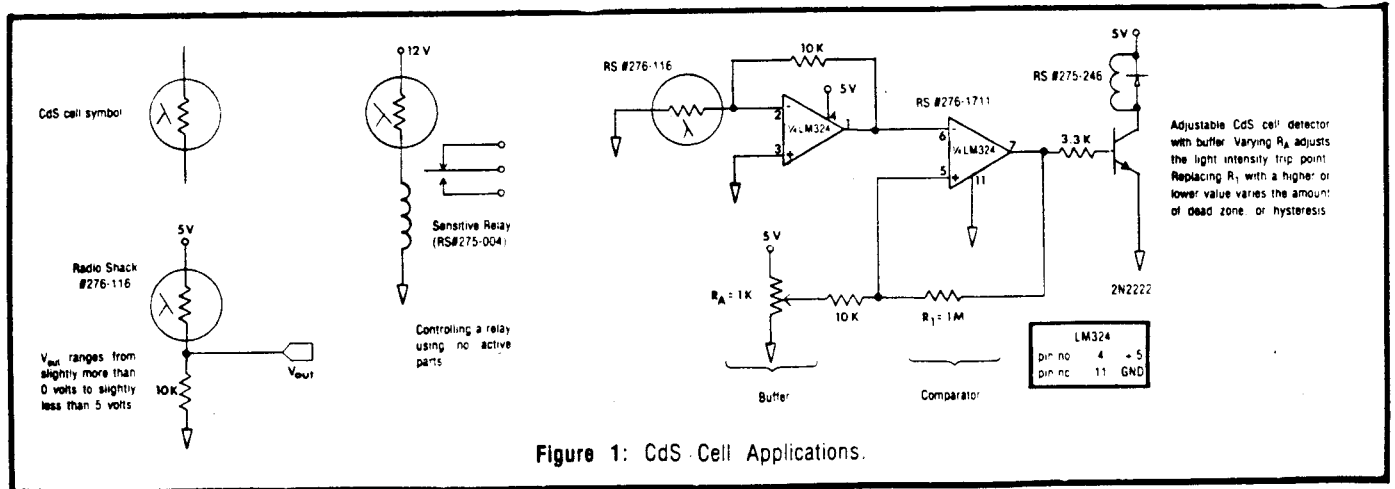

Figure 1: CdS Cell Applications.

volts minimum input voltage. By adding a cheap 2N2222 transistor we can do it. See how the equations in Figure 3 are used to determine the component values.

Many manufacturers make a photoswitch which is nothing more than an LED and phototransistor housed in a case. A slot between the two allows a flag to pass through and measure whatever is desired. Some common applications are: motor speed, velocity of the flag via time spent in the slot combined with length of the flag, non-contact detection of the edge of a piece of paper or metal, and most

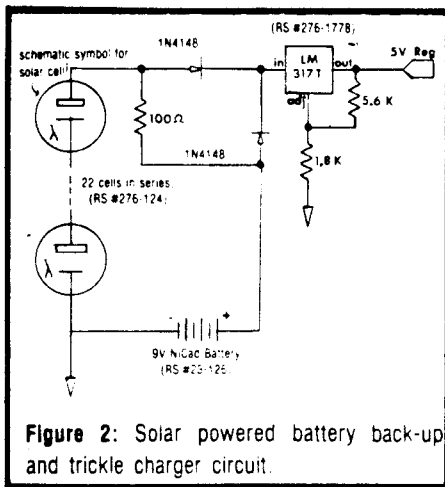

Figure 2: Solar powered battery back-up and trickle charger circuit.

commonly, an optical limit switch. If you want, you can easily make your own photoswitch by soldering an LED and phototransistor to a DIP (dual inline package) component header.

If the flag moves slowly through the slot, a possibility exists of multiple transitions on the output caused by the flag being in the active region of the transistor. A common solution is the use of Schmitt trigger gates such as the 7414s and 74LS14s or the use of a comparator with hysteresis. These are shown in Figures 4a and 4b. The circuit in 4b is more adjustable because it allows for independent variation of the trip point and the amount of hysteresis. This is useful in electrically and mechanically noisy environments. Figure 4c shows two photoswitches arranged to have a flag fly between them. The flag is longer than the distance between the photoswitches. By letting the two signals drive a D-flop it is easy to determine the direction of movement of the flag. By monitoring one of the signals, you can note when the flag moves through, how long it took and what direction it moved. A novel application would be to arrange two CdS

cells about 6 inches apart. These would be the two inputs to a circuit which could be placed at a store entrance to see what the flow of people in and out of the building is like.

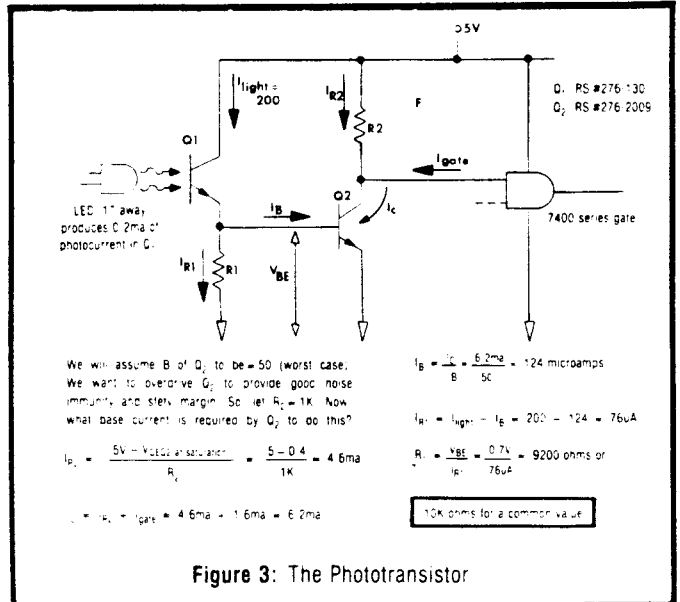

Figure 3: The Phototransistor

Figure 5 shows this circuit taken a bit further. Here, an optical encoder sits in the gap of the photoswitches providing a continuous measurement of shaft velocity and rotation direction. This type of encoder is called the incremental type as opposed to the absolute type. An absolute encoder has a unique digital code for every angle increment. An incremental encoder only has two channels or tracks, but with the use of counting circuitry it is easy to know where we are. An absolute encoder is only used where it is crucial to know the position of the shaft after power-up following the interruption of power. Optical encoders are used in robotics for joint angle, wheel velocity and position feedback. The problem with the circuit is vibration of the encoder disc, a common problem with anything mechanical. This translates into wildly oscillatory electrical noise at the output of the encoder's photoswitches. The CLOCK input is

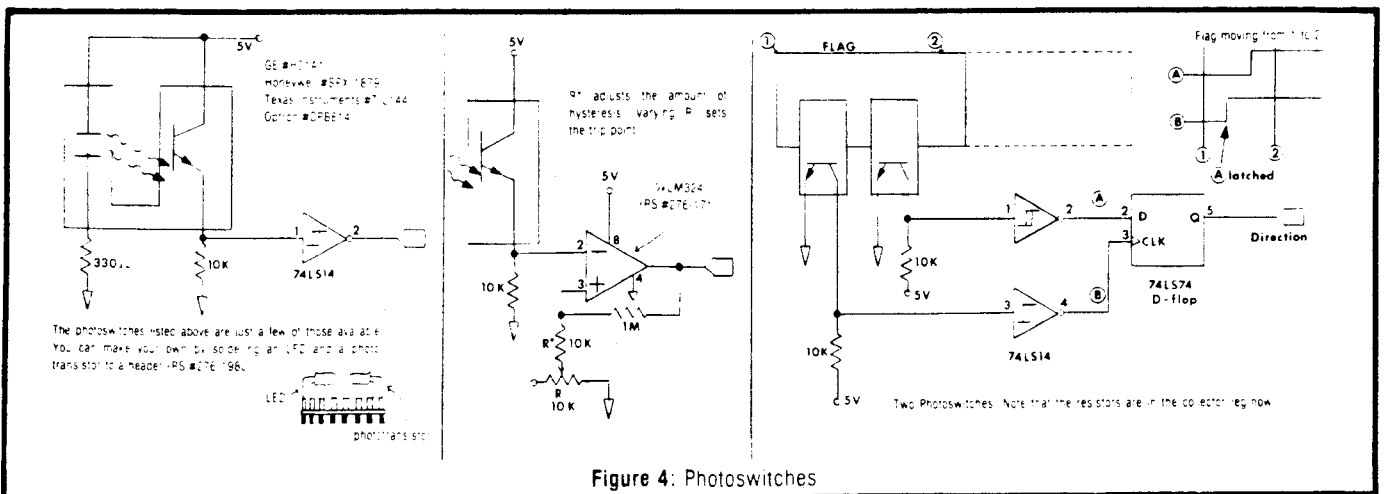

Figure 4: Photoswitches

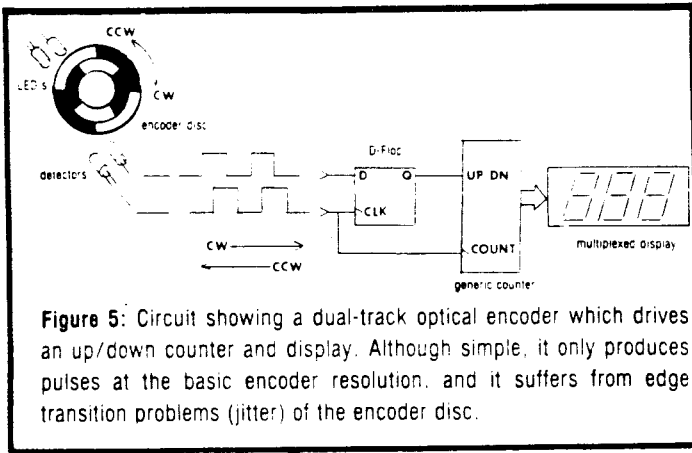

Figure 5: Circuit showing a dual-track optical encoder which drives an up/down counter and display. Although simple, it only produces pulses at the basic encoder resolution, and it suffers from edge transition problems (jitter) of the encoder disc.

also the input to the counter, and the counter would continue to register counts even though the encoder were stopped (because of mechanical vibration, the counter continues to accumulate counts).

Figure 6 shows the solution to the problem in the form of an electronic protractor. The solution is to high speed sample the two encoder outputs and also take a look at the last two samples. The latch, wired as a two channel, 2 bit shift register, accomplishes this nicely. A PROM coded appropriately makes the rest easy. We now have four outputs, the current and the previously sampled A and B signals from the encoder. These 16 combinations result in four forward, four reverse, four no change and four illegal states. The illegal states occur if the encoder is turning so fast that a state is skipped over.

To make a protractor, though, we need a few other inputs to the PROM. We also have to know if the counter is at zero and if the minus sign is off or on. Example: If CW rotation is to be an increasing angle as shown on the display, and if we are at minus 3 and rotating CW, then the counter must be

forced to count down in absolute value until zero is reached, at which time the PROM turns off the minus sign and signals the counter to start counting up. The circuit actually multiplies the resolution of the encoder by producing up and down pulses for every state. You can halve or quarter the resolution by counting only every other state or every fourth state respectively.

Encoders are expensive. The one used here has 900 counts per turn and hence the circuitry allows for 0.1 degree resolution. It costs about \$100, but do not fear. Manufacturers are producing modular or kit encoders for around \$25 to \$50. They don't have the resolution that their expensive counterparts do, but they fit a lot of application areas. Table 1 gives a partial list of modular encoder suppliers.

Two interesting applications that the author has used for the protractor are shown in Figure 7. The shop protractor finds use in sheet metal and drafting work. The electronic level is used in (of all places) race car wheel alignment. It is important to measure the caster and camber of the car's tires quickly. Conventional measuring techniques used plumb wires and rulers. With the electronic level, all one has to do is power-up the system when the bubble vial attached to the case indicates level. When the unit is turned on, all subsequent measurements are referenced from gravity through the use of the pendulum. Figure 8 is a photo of the protractor with the encoder exposed.

Photodiodes are similar to phototransistors except they are a pn junction device. They are less sensitive but hundreds of times faster than phototransistors. Normal sensitivities (or responsivity as it is sometimes called) range from about 0.05 to 0.7 amps per watt of input optical power.

A photodiode is modeled as a current source, a shunt resistance and a shunt capacitance. When no voltage is applied across the pn junction in Figure 9, the depletion region is narrow. Reverse bias voltage widens the depletion

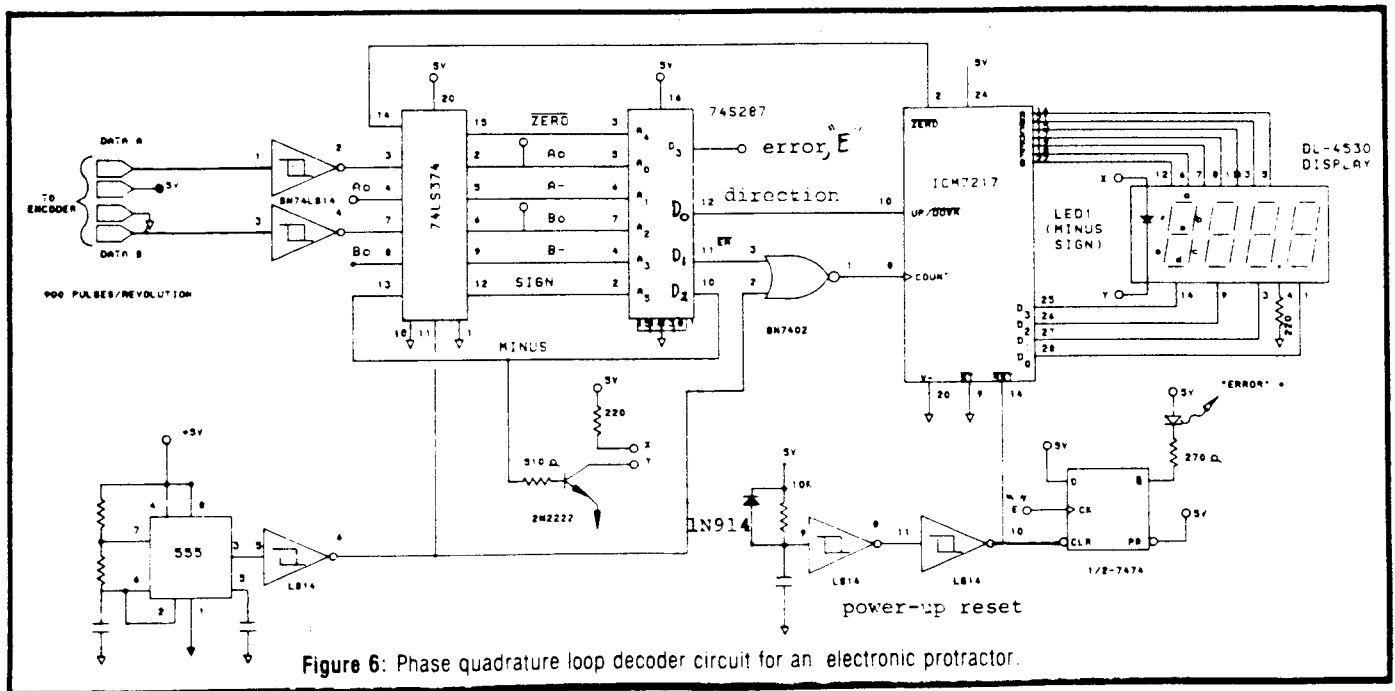

Figure 6: Phase quadrature loop decoder circuit for an electronic protractor.

Manufacturer	Encoder Name
a priori 21318 125th SE Kent, WA 98031 206-630-2144	JNIDISC
Hewlett-Packard 3000G Hanover St. Palo Alto, CA 94394 415-857-8000	HEDS-500 and HEDS-1000
U.S. Digital 5405 Garden Grove Blvd. Westminster, CA 92683 174-895-4556	SOFTPOT
Sensor Technology 21012 Lassen Street Chatsworth, CA 91311 213-882-4100	DYNAPOT
Litton Encoder Division 20745 Nordhoff Street Chatsworth, CA 91311 213-341-6161	MODELS 715 and 81

Table 1

region until it reaches the back n+ contact (at high reverse bias). The diode is now said to be operating in the fully depleted mode. Only the depletion region will support an electrical field.

When light strikes the diode, electron-hole pairs accumulate in the n and p regions respectively, causing a potential difference. If the light is strong enough to overcome the self-generated electrical field, recombination of the charge carriers oc-

curs at a rate great enough to cause current to flow.

Figures 10a, b, and c show the three ways a PIN (Positive-Intrinsic-Negative) photodiode can be used. All modes have their advantages and disadvantages. Figure 10d shows the current versus voltage curves for a photodiode at different levels of illumination. The load lines represent the volt/ampere characteristics of a load connected to the diode in the manner shown.

•**Load line a, photovoltaic mode.** The load resistor is greater than the shunt resistance of the diode. Because R_{shunt} varies widely in production batch processing, this is a poor way to design a circuit that would depend on this parameter. Its logarithmic response may be useful in photographic applications.

•**Load line b, photoamperic mode.** Here the diode is still at zero bias, but now the current flows mostly in R_{load} , an element we control. Output is linear and low noise. Response is slow due to the high capacitance of the depleted region. Remember, as the reverse bias voltage increases, the width of the depleted region increases and its capacitance decreases. This brings us to:

•**Load line c, photoconductive mode.** Here the diode is

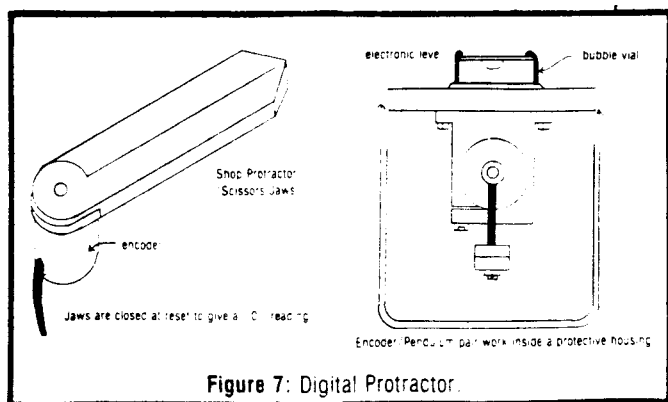

reverse biased and the junction capacitance is very small. Thus higher frequency operation is possible. But leakage current increases roughly as the square root of the bias voltage. Consult the manufacturer's data sheet for detailed information. This is the way most photodiodes are operated. Figure 10 shows typical circuit topologies.

Now we have all the tools needed to design a complete optoelectrical system. We can calculate or

measure the power from a source. We can find out what the power is at the surface of a detector located away from the source. But there is one final point that has to be discussed. It is the demon of most optoelectronic systems—noise. Since there are many ways for a signal to get corrupted as it travels from source to detector, it is perhaps the most important concept to understand. For if we know how much calculated noise there is going to be, we can plan ahead for the rest of the unanticipated sources of noise by cranking up the gain there, filtering here and aiming over there. The good news is that there are only two major sources of noise with which we have to be concerned: Shot noise and thermal noise.

Shot Noise

Shot noise is that noise associated with the discreteness of the electron. At low current levels this becomes more and

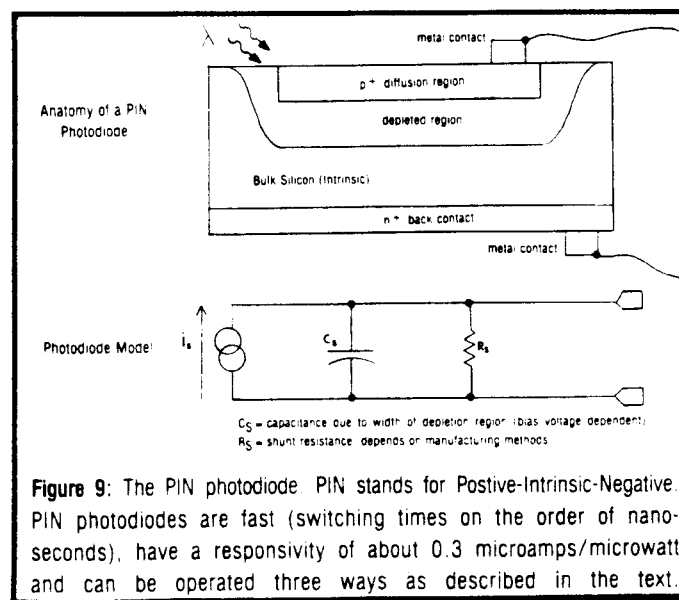
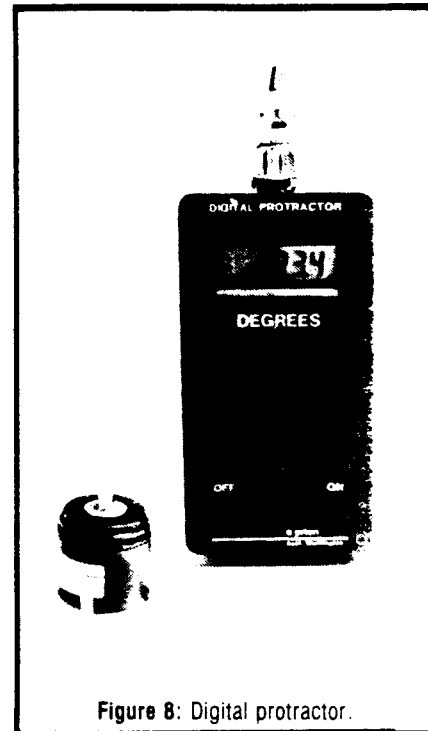

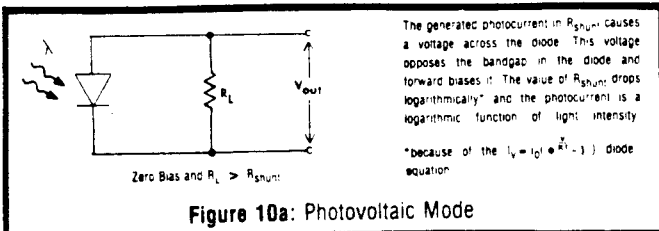

Figure 10a: Photovoltaic Mode

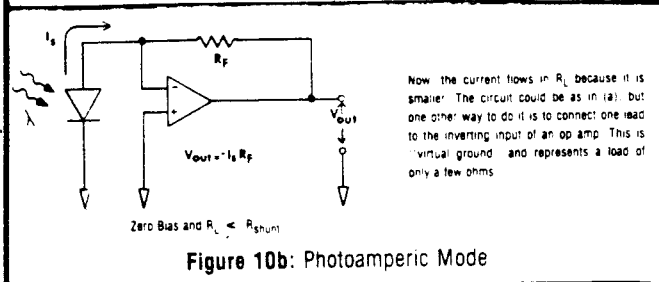

Figure 10b: Photoamperic Mode

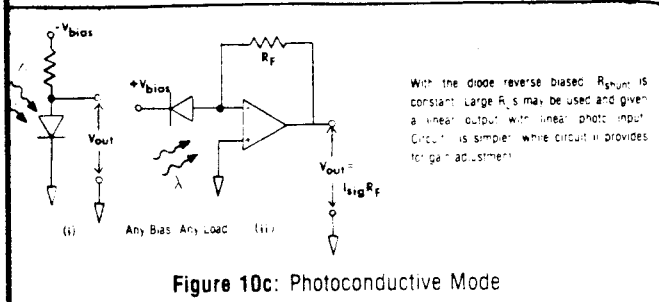

Figure 10c: Photoconductive Mode

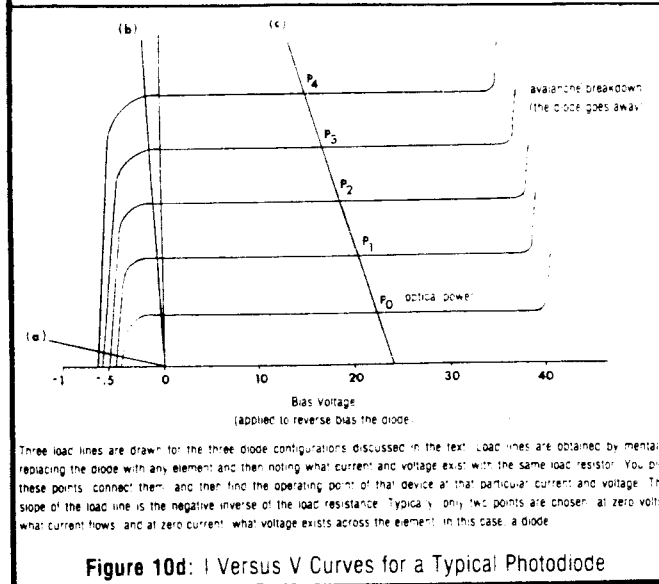

Figure 10d: I Versus V Curves for a Typical Photodiode

more noticeable as "hash" or white noise on an oscilloscope. When a solid state pn junction is reverse biased there is leakage current flowing. It is small, but contributes to Shot noise according to an equation derived from solid state physics.

$$I_{SHOT} = \sqrt{2q I_L B}$$

I_L = leakage current in amps
 q = electron charge (1.6×10^{-19} coulombs)
 B = bandwidth of system

As an example, what Shot noise current exists for a photodiode with 10 na of leakage current operating over a 10 KHz bandwidth?

$$I_{SHOT} = \sqrt{2(1.6 \times 10^{-19})(10^{-8})(10^4)} = 5.6 \times 10^{-12} \text{ amps} = 5.6 \text{ pA (picoamps)}$$

Most of the time you will see the noise given as amps per root Hertz. It is up to you to calculate the noise by including the bandwidth of your application.

Thermal Noise

There is voltage across a resistor just sitting on a table! This is due to the random thermal vibrations of the electrons in the resistor material. It is the electrical equivalent of the Brownian motion of molecules in a liquid or gas. As an analogy, a glass of water may appear to be quiet and still, but a close microscopic examination would reveal lots of active and vibrating water molecules. There is no useful flow of water in the glass, just as there is no useful voltage across the resistor. The thermal noise, or Johnson noise as it is sometimes called, is random in nature. This noise figure is also derived from equations in physics.

$$V_{THERMAL} = \sqrt{4KTRB}$$

k = Boltzman's constant (1.38×10^{-23})
 T = temperature in Kelvin ($K = \text{Centigrade} + 273$)
 R = resistance in ohms
 B = bandwidth in Hertz

For photodiodes, noise at low reverse bias is predominantly thermal and at high bias it is mostly Shot. However, amplifier noise can completely swamp out these two noise sources, so be sure to check the noise figures of the particular op amp that is used.

These two noise figures are uncorrelated and random. One does not affect the value of the other. Because of this, their values do not add algebraically, but according to:

$$N_T = \sqrt{N_1^2 + N_2^2 + \dots + N_n^2}$$

N_T = total noise
 N_1, \dots, N_n = the individual noise terms in either volts or amps.

Another way to talk about these noise terms is that they are "white noise" sources. This means that they have equal amplitude throughout the frequency spectrum.

Hardware Design and Noise Calculations for an IR Transmitter and Receiver

We will now go completely through a design problem which consists of an IR transmitter and receiver for remote controlled applications. What will not be covered are the communication protocols used. It is up to you to design for ASCII, binary, or any other format you might want. Also, we will not concern ourselves here with sophisticated detection methods such as phase locked loops(PLL) or fourth

order Butterworth filters. These topics are fairly well covered in soft cover books available at the suppliers mentioned in last month's article. What will be covered in quite some detail is the optoelectronics used and how choices are made. Noise calculations will be done in parallel with the hardware design. In this way we can see problems crop up early on in the design and take steps to correct them.

The transmitter will consist of the popular 555 timer driving an IR LED. The frequency will be 10 KHz at a 50% duty cycle. While we could do this problem in the DC world, there are a lot of problems with DC amplifiers and stray IR sources on the receiver's field of view. So we will assume a nice, reasonable bandwidth that gives us something to work with at normal data rates and also exposes us to the sometimes confusing world of noise terms and calculations. The LED used here has a cone half angle of 10 degrees. If we want to narrow that down, we can use a small, short focal length lens placed one focal length away from the tip of the LED. This will increase the range, but narrow the divergence angle and hence place stricter aiming requirements on the transmitter. In the case of a fixed installation for IR communications this poses no problem. If, on the other hand, this is to be used as a TV controller, we will want to dispense with the lens in favor of a wider operating field. Figure 11 shows the transmitter design. The IR LED used here put out a total of 1 mw of power.

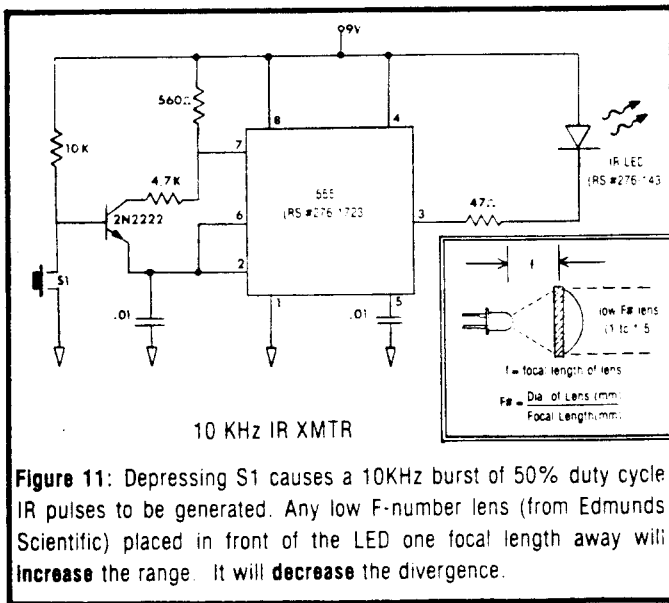

Figure 11: Depressing S1 causes a 10KHz burst of 50% duty cycle IR pulses to be generated. Any low F-number lens (from Edmunds Scientific) placed in front of the LED one focal length away will increase the range. It will decrease the divergence.

We assume we want to operate the transmitter at a distance of 3 m. Further, we have to take into account the possibility that the aim will be at ±10 degrees, the half angle. This is where the irradiance falls to 0.707 (1/sqrt 2) of its on-axis value. This is called "worst case" analysis and it must be done to insure that the specifications of the system are met.

First we must calculate the steradian value of the transmitter's 10 degree cone half angle using the equation that relates half angle to steradian measure:

$$\Psi = \pi\theta^2 = 3.14 \times \left[10 \text{ degrees} \frac{2\pi \text{ radians}}{360 \text{ degrees}} \right]^2 = 9.6 \times 10^{-2} \text{ steradians (sr)}$$

Taking into account the 0.7 mw of power from the worst case aiming of the 1 mw LED, we get a radiant intensity of:

$$\frac{P}{\text{solid angle}} = \frac{0.7 \text{ mw}}{9.6 \times 10^{-2}} = 7.3 \frac{\text{mw}}{\text{sr}}$$

Now we tackle the receiver. The lensed head of the TIL 413 focuses all the IR energy striking it onto its sensitive surface. From data sheet information we see that the head has a diameter of 5 mm. We then have to calculate how much steradian angle the receiver subtends at a distance of 3 m. We showed previously that this is equal to:

$$\Psi = \frac{A}{R^2} \text{ where } A \text{ is the area and } R \text{ is the radius}$$

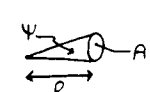
$$= \frac{3.14 \times (2.5 \text{ mm})^2}{(3000 \text{ mm})^2} = 2.2 \times 10^{-6} \text{ sr}$$

To find the power at the receiver's photodiode, we multiply the radiant intensity from the transmitter by the solid angle subtended by the receiver at 3 m:

$$P_{\text{received}} = \Psi = 7.3 \frac{\text{mw}}{\text{sr}} \times 2.2 \times 10^{-6} \text{ sr} = 1.6 \times 10^{-8} \text{ W} = 16 \text{ nW (nanowatts)}$$

We also note that the responsivity of the photodiode is 0.5A/W. This is measured at the wavelength we will be using. It is a measure of how efficiently the photodiode turns photons onto electrons. So the current that flows in the receiver circuit due to the light output from the LED 3 m away is:

$$I_{\text{signal}} = RP = \frac{0.5 \text{ A}}{\text{W}} \times 1.6 \times 10^{-8} \text{ W} = 8 \times 10^{-9} \text{ A} \text{ or } 8 \text{ nA ; our signal}$$

What are the two noise terms? We find that this photodiode has 10 na of leakage current when operated at a reverse bias of 15 v. The Shot noise over our 10 KHz bandwidth is:

$$I_{\text{SHOT}} = \sqrt{2 \times 1.6 \times 10^{-19} \times 10^{-8} \times 10} = 5.7 \text{ pA} \text{ or about } 1400 \text{ times smaller than our signal.}$$

For thermal noise, we assume room temperature operation at 23 degrees Centigrade or 293 degrees Kelvin. But what resistor are we talking about in the following equation?

$$V_{\text{Johnson}} (\text{volts}) = \sqrt{4KTRB}$$

Figure 12 shows that this is the feedback resistor in the op amp detection circuit. This configuration is called a current-to-voltage converter or trans impedance-amplifier. In order to calculate the thermal noise we first must pick this resistor. The circuit in Figure 12 produces $(I_{\text{signal}} \times R_{\text{feedback}})$ volts. Now we have to make another assumption. How many volts do we want at the output of the op amp at this point? It has to be low for two major reasons. First, the receiver has to work with the transmitter very close to it. If there is too much gain, then the receiver will take a long time to get out of saturation every time the transmitter "blinds" it.

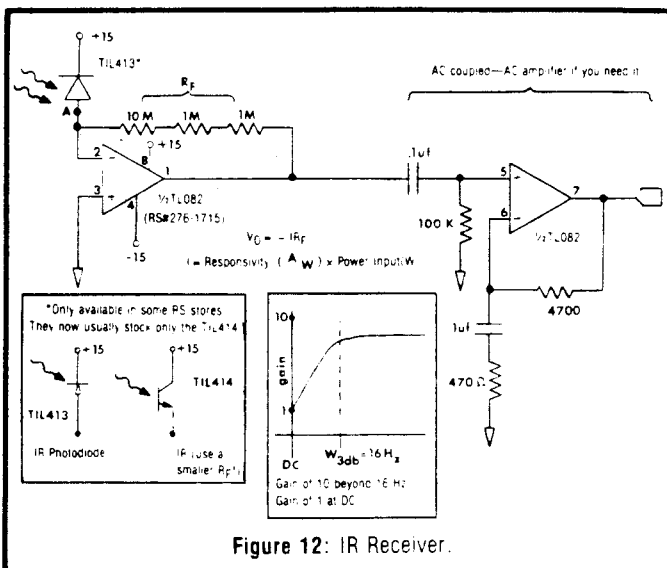

Figure 12: IR Receiver.

Second, the higher the feedback resistor, the less the frequency response of the receiver. It also means more thermal or Johnson noise since this noise varies as the square root of the resistance. This seems like a quandary: we can't calculate the total noise until we know the value of the feedback resistor, but fixing the resistor also fixes the signal gain and hence the output voltage and noise. Where do we start? This is a common dilemma in electronics; we need to know the answer in order to solve the problem! The approach usually taken is an iterative one. Start somewhere, do the calculations and see if what you get is "good enough". If not, then change some value somewhere that will give a different overall response in some area and re-calculate. You will see the trade-offs occurring and it is up to you to decide when to stop.

In this particular example, the starting place will be the output voltage from the first op amp. We pick a voltage that we want to have when the IR LED is operating at 3 m. This imposes a certain feedback resistor. If this results in too much thermal noise, then we lower this resistor and add gain somewhere else, perhaps in a following stage of

amplification. We pick 0.1v.

$$\text{So, } 0.1 \text{ v} = R_{\text{feedback}} \times 8 \text{ na}$$

$$R_{\text{feedback}} = 12.4 \text{ Megohms}$$

We will use a 10 Megohm in series with two 1 Megohm resistors

The thermal noise is:

$$V_{\text{THERMAL}} = \sqrt{4 \times 1.38 \times 10^{-23} \times 293 \times 12.4 \times 10^6 \times 10^4}$$

$$= 4.5 \times 10^{-5} \text{ volts}$$

And our 5.7 pA Shot noise current contributes:

$$V = IR = 5.7 \times 10^{-12} \times 12.4 \times 10^6$$

$$= 7 \times 10^{-5} \text{ volts of noise}$$

Both noise terms contribute somewhat equally. Usually one or the other dominates, but here this is not the case. Using our equation for total noise from uncorrelated sources we get:

$$V_{\text{TOTAL}} = \sqrt{(7 \times 10^{-5})^2 + (4.5 \times 10^{-5})^2}$$

$$= 8.3 \times 10^{-5} \text{ volts}$$

Thus our signal-to-noise ratio at 3 m is:

$$S/N = \frac{0.1 \text{ V}}{8.3 \times 10^{-5} \text{ V}} = 1204$$

So we have a thermal noise limited system. There are two ways we could lower this figure even more. We could shop for a lower leakage current photodiode or we could lower the temperature of both the diode and the resistor. In fact, lots of commercial IR detectors or thermal scanners used in taking heat maps or thermograms of houses or human bodies use liquid argon cooled detector. These are expensive methods, but it is nice to know how to lower the noise figure.

We mentioned amplifier noise earlier. The TLO82 from Texas Instruments used here is a dual Bi-FET. We will use the other op amp in the package as an AC coupled, AC amplifier. This will roll off any frequencies below 16 Hz and block any static DC terms caused by large IR sources such as reflected sunlight off a road surface or a fire in a fireplace. Since this extra op amp exists, let's use it. What noise does the TLO82 contribute? The data sheet says 20 nanovolts per root hertz. This term is called equivalent noise input voltage. It means you can think of the op amp as being perfect, but with a noise generator permanently connected to the input, always mixing in with any other

signal. The noise generated is then:

$$V_{\text{OP-AMP}}^{\text{NOISE}} = \frac{20 \times 10^{-9} \text{ V}}{\sqrt{\text{Hz}}} \times \sqrt{10,000 \text{ Hz}}$$

$$= 2 \times 10^{-6} \text{ V} = 0.2 \times 10^{-5} \text{ V}$$

or about 15% of the Shot and Thermal values.

So the amplifier amounts to a fairly large percentage of the total noise. We could use even quieter op amps, but this is a commonly available one. Try LM11 or LM308 from National Semiconductor for impressive noise figures for only a few dollars.

Sources and Detectors

I haven't mentioned much about where and how to get IR LEDs, optical switches and photodiodes. The following is a partial list of companies that make a large assortment of opto-electronic hardware.

D = Detectors, S = Sources, OS = Optical Switches

Company	D	S	OS
Litronix 1900 Homestead Rd. Cupertino, CA 95014 408-257-7910	x	x	x
United Detector Technology 3939 Landmark Street Culver City, CA 90230 213-204-2250	x		
Centronic 1101 Bristol Road Mountainside, NJ 07092 201-233-7200	x		
General Electric Semiconductor Products W. Genesee St. Auburn, NY 13021 315-253-7321	x	x	x
TRW 1201G Tappan Circle Carrollton, TX 75006 214-323-2200	x	x	x
Hewlett-Packard 300G Hanover Street Palo Alto, CA 94304	x	x	x
Honeywell Optoelectronics Division 830 East Arapaho Road	x	x	x

Company	D	S	OS
Richardson, TX 75081 214-234-4271			
Texas Instruments Optoelectronics Marketing Box 10508 MS 5811 Lubbock, TX 79048 806-747-3731	x	x	x

Call or write these companies to get catalogs and literature. Most application or "ap" sheets give several good, practical circuits. When you definitely need just one part to complete a project, try this: Call up the company or their representative for your area (this information will be in the catalogs you receive). Tell them courteously and professionally that you would like a sample part for evaluation. When they ask for your company name, have one ready even if you don't work for a large Fortune 500 firm. It can be your own made-up company name. This is not dishonest. You really are doing serious circuit evaluation for you own one-person company. Do not abuse this accepted practice in the electronics field. Companies do this because they know that service provided now may lead to large orders from you later in your career.

To finish this month's article, we present an opto-electro-mechano application. Figure 13 shows the opto-electronics and mechanical parts to a vehicle tracking and steering system. Such a device is called a "servomechanism" and works using feedback. The purpose here is to provide the steering for a vehicle that is tracking a reflective tape laid down on the floor. The two phototransistors receive light from a centrally mounted LED or small light bulb mounted on the underside of the vehicle. This lights up the tape and reflects into the two detectors. The photocurrent is turned into voltage as before and the difference is taken with A3. When the vehicle is tracking properly, the difference is zero. When the vehicle starts to drift, the difference will no longer be zero and the output of the error amplifier A4 will go either positive or negative. This will command the motor on the steering box to turn in one direction or the other. A pot mounted to the steering shaft provides the feedback. The best place to purchase low cost gearboxes with motors attached to them is:

Edmund Scientific
101 E Glouster Pike
Barrington, NJ
800-257-6173

You will have to mount the pot to the output steering shaft. The two crucial points in any servo are the gain and proper wiring of the feedback pot. If the two wires from the top and bottom of the pot are reversed, then at the first sign of error voltage, the motor starts to turn. But the error will get bigger because the motor is "correcting" in the wrong direction. Eventually the limits of travel on the pot will be reached, the motor will stall and start to heat. Either

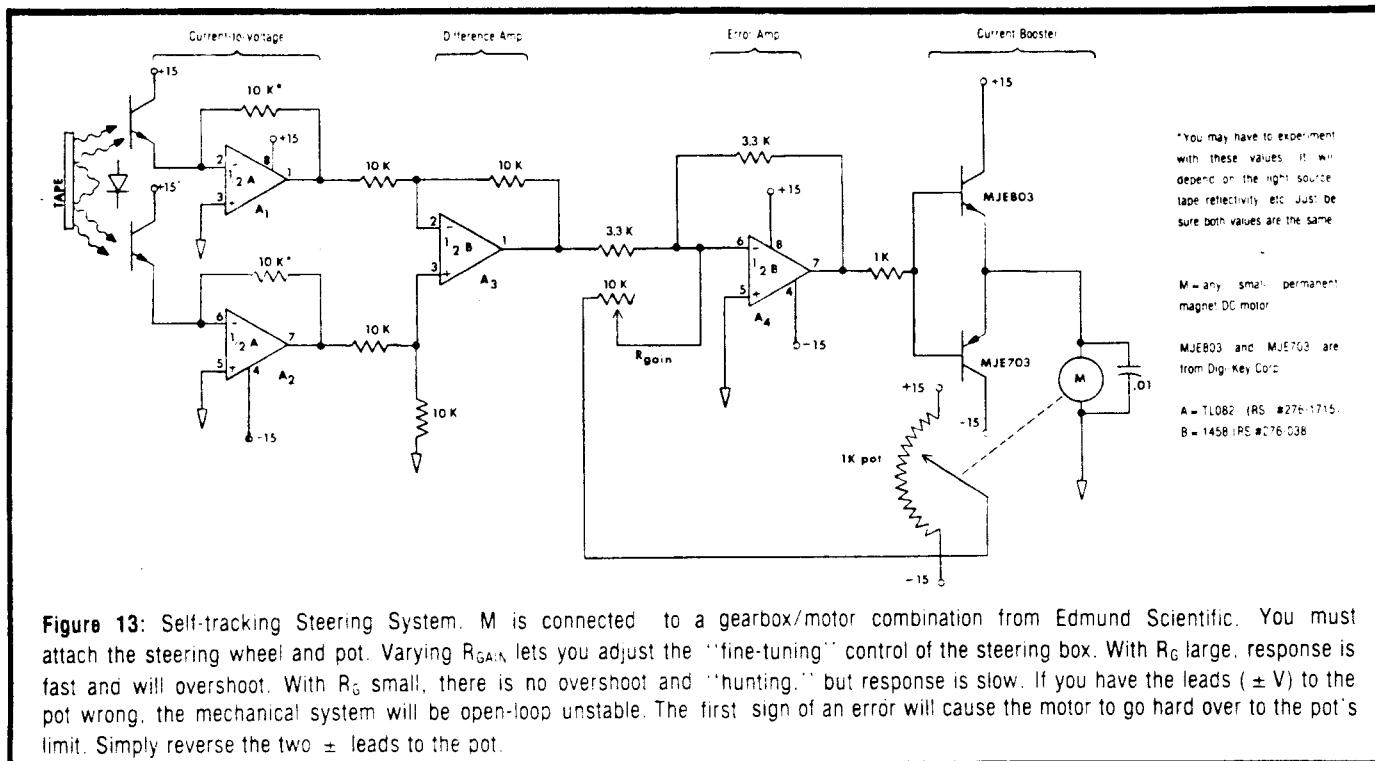

Figure 13: Self-tracking Steering System. M is connected to a gearbox/motor combination from Edmund Scientific. You must attach the steering wheel and pot. Varying R_{GAIN} lets you adjust the "fine-tuning" control of the steering box. With R_G large, response is fast and will overshoot. With R_G small, there is no overshoot and "hunting," but response is slow. If you have the leads ($\pm V$) to the pot wrong, the mechanical system will be open-loop unstable. The first sign of an error will cause the motor to go hard over to the pot's limit. Simply reverse the two \pm leads to the pot.

reverse the leads to the motor or to the pot.

The other important parameter is the gain pot, R_G . A_4 is wired as an inverting summing op amp configuration. If R_G is larger than 3.3K the overall gain of that leg is less than 1 and the response of the motor is slow but it will not overshoot. If you adjust R_G to be less than 3.3K, the gain will be greater than 1. The error amplifier generates large outputs for small inputs. This gives a fast steering response, but the motor will always overshoot its mark and then will make a correcting action in the other direction. This is called "hunting and searching" in servo jargon. It is the same thing you did to the steering wheel of a car when you first started learning how to drive. You made large corrections too quickly and the result was an oscillatory car.

This is just a first step into servomechanisms and we will go no further than this. You will have fun exploring optical tracking of vehicles with this type of controller. The signal at point A is simply an indication of which detector has more light on it. Some of the companies listed above have quadrant detectors used to tell where a beam of light is on the surface of the detector. This finds use in laser beam alignment of boring machines in tunnels, the tracking of the playback mechanism in video disk players and in solar tracking of parabolic mirrors used in solar energy power generation. Figure 14 shows electronically and mechanically how you can build your own quad detector from four low cost phototransistors. How you use the x and y outputs is up to you.

In the third and final article we will discuss opto-couplers and their uses, fiber optics and applications, and simple optics, using readily available simple lenses to increase the range of IR devices or to couple LED's and detectors. ■

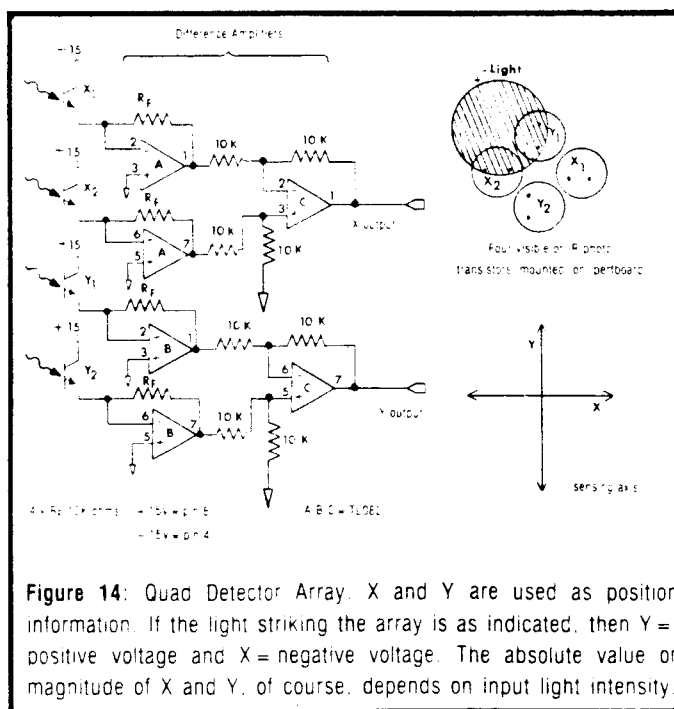

Figure 14: Quad Detector Array. X and Y are used as position information. If the light striking the array is as indicated, then Y = positive voltage and X = negative voltage. The absolute value or magnitude of X and Y, of course, depends on input light intensity.

Roger Johnson is associated with a priori, 21318 125th SE, Kent, WA 98031. a priori is a manufacturer of modular electro-optical and mechanical parts for position encoding.

Multi-user

A Column by E.G. Brooner

In the first column of this series we mentioned the three general classes of multi-user systems. This time we'll describe the "multi-processor" class of systems in a little more detail and describe a couple of typical products that are available off the shelf right now.

Multi-processor systems are a relatively new idea - newer, in fact, than the LANs (Local Area Networks) with which they most directly compete. They have been made possible, logically enough, by new "chip" technology which lets us put a lot of "bits" and "bytes" in a small space. Cheap and compact memory lets us have single board computers (containing for example, a CPU, I/O port and 64K of memory) that are relatively small and inexpensive. Add a terminal and you have a viable single-user computer system.

Multi-processor systems pack several such little computers in a single cabinet, no bigger than the average desktop unit, and extend cables to the associated terminals. They usually feature a disk storage system, and one or two printers, which have to be centrally located and are shared by everyone connected into the system.

Multi-processors are sometimes referred to as a "network-in-a-box." Although we didn't discuss network (LAN) communications systems in detail, we did mention earlier that they were fairly expensive and rather complex. Using the network-in-a-box concept eliminates a lot of the complexity, as the "communication" all takes place within a few inches, using the S-100 bus itself as the transmission system.

How do costs compare? A multi-processor, at 1983 prices, can be configured with 4 users (and some shared peripherals) for under \$10,000. Compared with a time-sharing system of the same make and/or quality, the multi-processor is a bit more expensive. It would be slightly less than a network of comparable quality, and in the same general price range as an equal number of separate microcomputers.

Performance? The network, in any such comparison, would probably operate much faster than either the timeshared or multi-processor system. It would also lend itself more readily to an operation spread over a few thousand yards or a few miles, and might provide some extra features not found in the simpler systems. It could, for example, be expanded to a larger size if such expansion ever became necessary; multi-processors, much like timesharing systems, do have a fairly low limit on the number of users they can serve. They are also less flexible than networks in the matter of communicating directly between users.

For small installations that intend to stay small (from 2 to a dozen or so workstations) and in which the stations are reasonably close to the central point, the multi-processor

may well be the best choice. The cost in this size range will be comparable to a similar number of separate microcomputers, but the result will be a more versatile operation. Above this size range, networking is really the only practical choice. We'll go into networks in a later issue.

North Star Computers (San Leandro, CA) has been making a computer called the Horizon[®] since before most of us even heard of personal computers. It has traditionally been in the middle price range, between the mass produced micros and the really deluxe business versions. This computer, up until just recently, contained a group of plug-in boards of the standard S-100 configuration (100 pin, about 5"

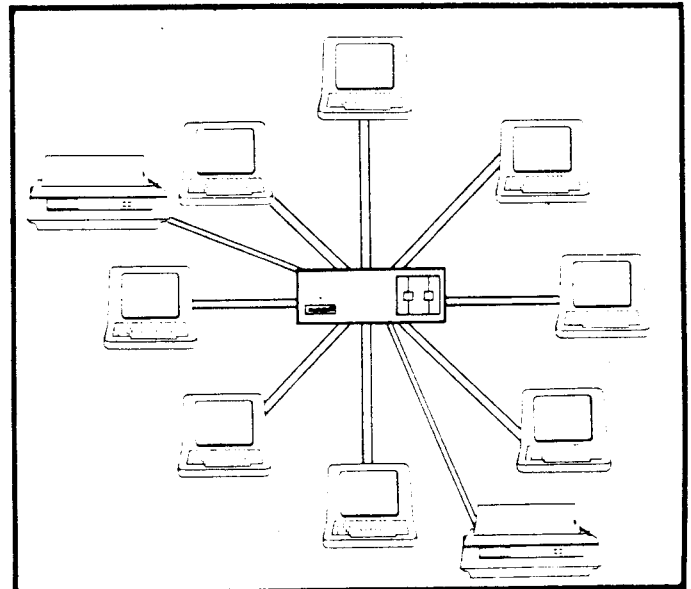

The HORIZON multi-processor system supports up to eight users.
(Courtesy of North Star Computers, Inc.)

by 10" in size). The different boards performed different functions and there were a lot of extra slots for expansion and add-on features. This basic machine turned out to be easily adaptable to the multi-processor idea.

North Star's new single board computer is the same size and sells for about the same price as their original Horizon CPU board, but instead of being just a CPU, it contains 64K of memory and two serial ports. A number of these, plugged into the Horizon "mainframe," or S-100 bus, is the basis for a multi-processor system. The other key ingredient (in addition to the multiple single-board computers) is the Turbo-DOS software package. Turbo-DOS is an operating system which superficially resembles CP/M[®] and is in many ways compatible with it.

The result (so far as cost is concerned) is this: the basic Horizon used to sell for around \$3000 without printer or

continued on page 17

TRUE RMS Measurements

by Robert L. Bauman

Introduction

Ever since the National Bureau of Standards began using RMS* techniques for measuring AC signals, most AC-measuring instruments are calibrated to display values in RMS units, although the average value of the rectified waveform is actually measured. It is often difficult to determine the true accuracy of an AC measurement, since accuracy depends upon measurement technique and waveform characteristic. To minimize cost, most AC instruments measure the rectified average value of the AC signal, and then convert this value to a RMS equivalent by assuming that the signal is a perfect sine wave. Thus, most AC-measuring instruments only measure the true RMS value of a signal when the signal is a perfect sine wave.

For the person making the measurement, the problem is to recognize what quantity is actually being measured. The difference between what the operator thinks he is measuring and the parameter he is actually measuring can lead to embarrassing inaccuracies. This is especially important when you are working with the accuracies common to digital instruments. Figures 1 through 3 illustrate the discrepancy between true RMS values and average responding values calibrated in RMS units for typical measurements.

Wave Form Characteristics

If a single number is to be used to characterize the magnitude of an AC signal, a choice exists for the most useful value. There are three commonly used values; peak, rectified average, and RMS.

With an oscilloscope, you usually measure the peak or peak-to-peak value of an AC signal, as this is the only value that can be determined from the waveform by visual inspection. This is also the critical value for determining whether an unknown signal will overdrive an amplifier. However, the peak value does not give enough information in many applications. As an example, random noise has infinite peak value; thus, it cannot be measured with a peak-detecting instrument.

At first glance, it would seem that the average value of a wave form would be more useful. This value depends upon the complete wave form, not just upon one point as with peak value. Unfortunately, average value seldom occurs in the mathematical treatment of wave forms. Thus, it is a relatively unimportant parameter, even though it is fairly simple to measure with an inexpensive rectifying circuit.

* RMS refers to root-mean-square. Its value is calculated by squaring the function, taking the average value, and then taking the square root of the function. Mathematically, it is expressed

$$E_{\text{RMS}} = \sqrt{\frac{1}{(t_2 - t_1)} \int_{t_1}^{t_2} e^2(t) dt}$$

In most cases, the third quantity -RMS value- is the most important AC signal parameter to know. For example, the power dissipated in linear circuits is directly proportional to the RMS voltage. The RMS value is so important that the National Bureau of Standards uses it to define the standard AC volt. This is why virtually all manufacturers calibrate AC voltmeters to RMS even when the AC conversion techniques used measures RMS only for the theoretical pure sine wave.

AC Voltage Standards

The AC standard maintained by the National Bureau of Standards consists of a reference group of thermoelements (vacuum thermocouples) and a set of thermal voltage converters. This is not a voltage standard in the sense that a bank of standard cells serves as a DC reference with a known EMF. Rather, the AC standards are transfer standards that relate AC voltage to the basic DC units of current and voltage.

The standards are used in a thermal transfer setup to compare the heating effect of an AC voltage to that of a standard DC voltage. Since absolute calibration of transfer standards is not possible, the thermoelements must be intercompared to establish their inherent AC-DC difference.

Secondary AC Standards

Several manufacturers offer instruments for use in standards laboratories for calibrating AC measuring instruments. These secondary standards also use a thermal

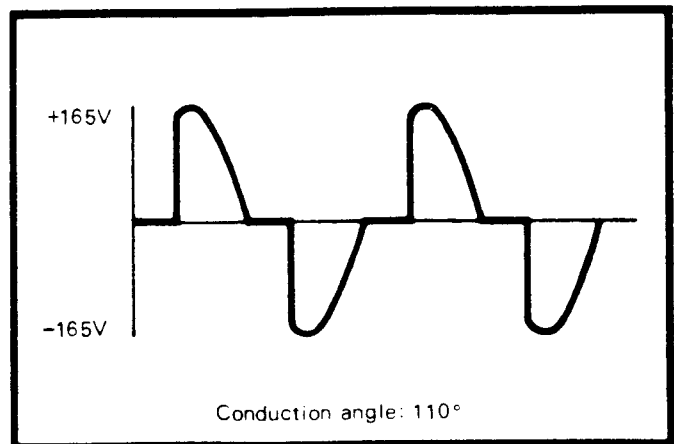

FIGURE 1. Value of load voltage using full-wave SCR phase control. This wave form demonstrates the pitfalls of assuming that an average-reading AC measurement calibrated in RMS units closely approximates the RMS value. For this example, the true RMS voltage is 98.6V RMS (42.1 dBm, reference 600Ω). Average reading value comes to 76.9V, error of this value is 22.0%.

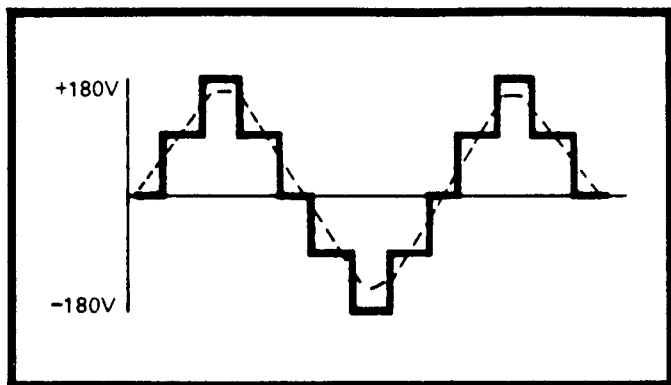

FIGURE 2. Sine wave synthesis by voltage switching.

$E_{RMS} = 110.2V_{RMS}$; 43.1 dBm (600- Ω reference).
 $E_{ave} = 99.9V_{RMS}$. Error with average response instrument calibrated in RMS units is 9.3%.

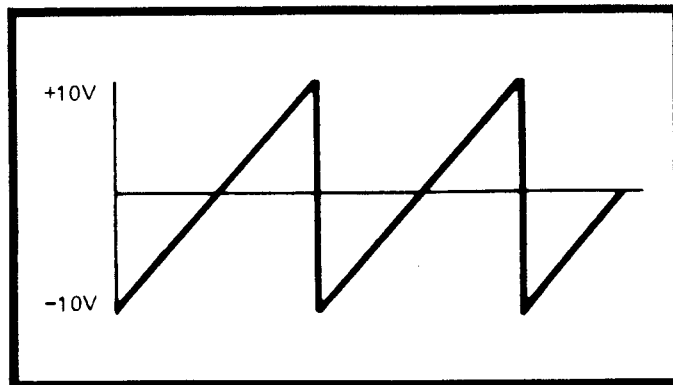

FIGURE 3. Sawtooth waveform.

$E_{RMS} = 5.77V_{RMS}$; 17.4 dBm (600- Ω reference).
 $E_{ave} = 5.55V_{RMS}$. Error with average response instrument calibrated in RMS units is 3.8%.

transfer-standard technique, similar to that used by the National Bureau of Standards. The test setup for a thermal transfer AC measurement is shown in Figure 4.

1. The range resistor is adjusted to scale the AC heater current to the effective range of the thermocouple.
2. A voltage, proportional to the RMS value of the AC current, is produced at the thermocouple junction. The thermocouple output causes a galvanometer deflection that is nulled out by adjusting the battery output to equal the AC voltage.
3. The calibrated DC source is switched in place of the AC input and adjusted to null the galvanometer. The calibrated DC voltage is now equal to the RMS value of the AC voltage.

This procedure is rather tedious: it requires two warmup periods for the thermocouple, two null balances, and usually a skilled operator.

Recently, voltmeters have been developed that automate the transfer standard technique. The RMS value can be displayed with little operator intervention. But a problem of high cost exists with instruments using the automatic thermal transfer technique. These voltmeters have extensive complex circuits to automate the measurements, to provide high output impedance, to protect the thermal element, and to increase the limited dynamic range of the basic thermocouple.

However, these voltmeters still have disadvantages inherent to the technique: measurement speed is slow—2.5 seconds—due to the response time of the thermocouple; sensitivity is limited by the thermocouple; minimum frequency response is limited to about 45 Hz because the thermocouple output will follow a low-frequency wave rather than provide the RMS value.

This causes manufacturers to continue to search for an economical instrument which has faster measurement speed, higher sensitivity, and lower frequency response. Given a trade-off between price and performance, most users would accept a voltmeter which gives a reasonable approximation of the RMS value of the AC signal at an economical price.

Non-Thermal True RMS Measurement Techniques

Using the building blocks of high speed analog computers, non-thermal RMS techniques have been developed to provide the accuracy previously available only with thermal RMS techniques. The critical element is analog circuitry that has a square law transfer function similar to that of a thermocouple. These circuits provide true RMS measurements compatible with the National Bureau of Standards. Yet, they avoid the problems associated with the thermal transfer measurement technique; high cost, poor reliability due to the excessive sensitivity of the thermal element, and poor low frequency response.

RMS Measurement Accuracy

Often one is interested to know the accuracy of a true RMS AC measurement on a specific waveform. The crest factor of the instrument is the key to answering this question.

No instrument will accurately measure the RMS value of all waveforms. The crest factor specification describes the set of waveforms on which the instrument will make measurements to the specified accuracy.

Obviously, an average responding instrument can not have a crest factor specification, since the average responding instrument will only measure one waveform—a sine wave—accurately.

The crest factor is expressed as a ratio of the peak amplitude to the RMS value of a waveform. An instrument with a 4:1 crest factor will measure to stated accuracy all waveforms with less than 4:1 crest factor. The crest factors of some commonly encountered waveforms are:

Waveform	Crest Factor
Sine Wave	1.41
Square wave	1.00
Triangular wave	1.74
Load voltage with SCR control (Figure 1)	1.68
Synthesized sine wave (Figure 2)	1.64
Saw tooth (Figure 3)	1.74
Pulse train (16:1 duty cycle)	4.00

The examples indicate that most common waveforms have relatively low crest factors. Waveforms with bursts of

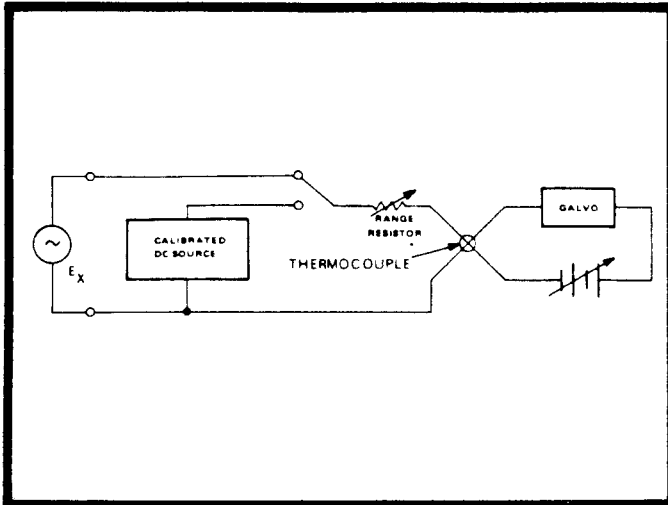

FIGURE 4. Thermal transfer standard technique measurement.

energy, like low-duty-cycle pulse trains, have high peak-to-RMS ratios, and thus can only be measured accurately with high crest factor instruments.

The crest factor specification of most true RMS measuring instruments varies with the magnitude of input signal as compared to the full-scale range of the instrument. The specification is better at one-half of full scale than at full scale. Table 1 lists the crest factor for various reading levels.

% of Full Scale	Reading	Crest Factor
200%	1999	2:1
100%	1000	4:1
50%	500	8:1
20%	200	20:1
10%	100	40:1

Table 1: Typical crest factor for various readings.

Average Responding Measurements

The average responding technique offers good stability, good sensitivity, and relatively fast measurement speed at an economical price. Its economy and effectiveness have led to its widespread use in automated instruments such as digital voltmeters.

Average responding converters would probably be much more popular except for a major drawback: small deviations from a pure sine wave in the measured signal can cause gross inaccuracies. The errors caused by this distortion are a result of the indirect nature of the technique; the converter is actually measuring the rectified average value of the AC signal and then displaying the value on a scale calibrated to the RMS equivalent. The key point is that the calibration is based on the precise mathematical

relationship between the average value and the RMS value of an undistorted sine wave. Mathematically,

$$E_{av} = - \frac{E_p}{2\pi} \int_0^{2\pi} \sin \theta \, d\theta = \frac{2E_p}{\pi}$$

$$E_{rms} = \frac{E_p}{\sqrt{2}} \int_0^{2\pi} \sin^2 \theta \, d\theta = \frac{E_p}{\sqrt{2}}$$

$$E_{rms} = \frac{\pi}{2\sqrt{2}} E_{av} = 1.11072 E_{av}, \text{ where } 1.11072 \text{ is the calibration factor } \left(k = \frac{E_{rms}}{E_{av}} \right)$$

The output of the average responding converter is multiplied by 1.11 to display the measurement in RMS units.

In practical situations, there are no undistorted sine waves. The typical power line has between 1% and 3% distortion. The best test oscillators are specified at 0.1%. With only 3% distortion, the accuracy of an 0.1% average responding converter can be degraded to 1% - an order of magnitude worse. Also, only a well trained eye can detect 3% distortion on an oscilloscope. In the case of a square wave, the accuracy of an average responding converter versus the true RMS value is degraded to 11%. The inaccuracy of an average responding instrument on other typical non-sinusoidal waveforms is shown in Figures 1, 2, and 3.

The inherent error of average responding measurements is a function of the magnitude, harmonic content and phase of the distortion. Examples of theoretical error caused by second and third harmonic distortion of the sine wave are shown in Figures 5 and 6*.

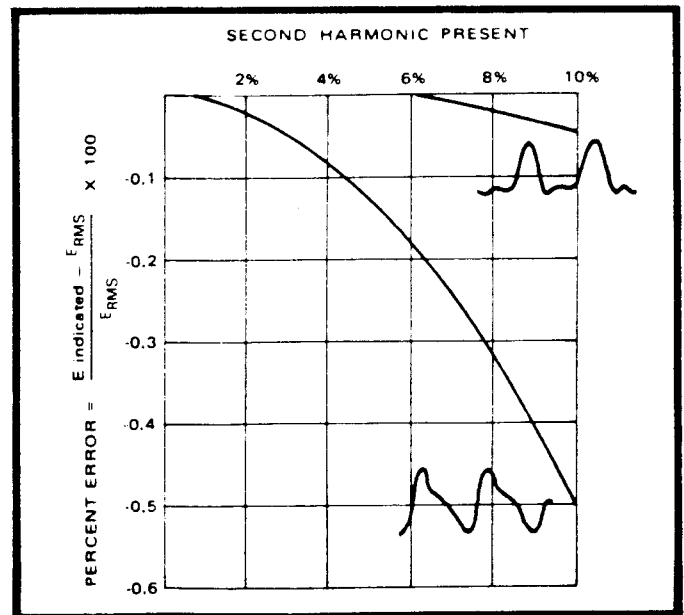

FIGURE 5. Measurement error due to 2nd harmonic distortion.

Peak Detecting Measurements

The peak detecting technique has been used longer than

*"RMS Measurement of AC Voltages," Frank C. Martin, Instrument and Control Systems, January 1962

any other indirect measurement technique. It measures peak amplitude and indicates RMS value in a conversion similar to average responding measurements.

Almost obviously, this technique is not suited for high accuracy AC measurements. Small amounts of distortion in a sine wave cause far more significant errors in peak detecting converters than in average responding converters. It is also inherently more susceptible to noise. Therefore, this technique is used only in inexpensive, multipurpose meters with accuracy rarely better than 5%.

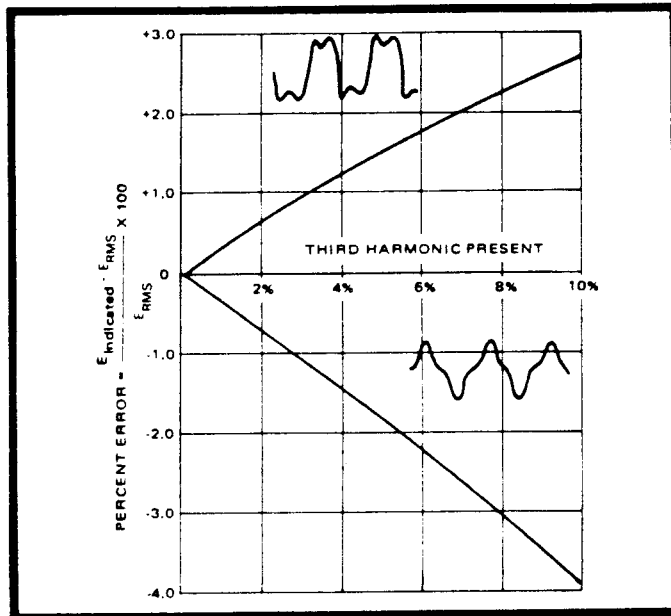

FIGURE 6
Measurement error due to 3rd harmonic distortion.

Summary

In probably no other type of measuring instrument is trade-off more important than with AC voltmeters. A very clear idea of the measurement requirements is needed to prevent buying too much or too little instrument. A decision must be made on the relative importance of accuracy, price and ease of operation.

If price and ease of operation are very important, an average responding AC voltmeter is best. If the most precise AC measurements are required, regardless of cost or difficulty of making the reading, a voltmeter using thermal-transfer techniques is the answer.

For the best balance between accuracy, cost and ease of operation, a voltmeter using a RMS computed circuit offers high value. ■

Robert Bauman is the Corporate Vice President of Hickok Electrical Instrument Co. of Cleveland, OH. Hickok manufactures test equipment for the types of measurements discussed in this article.

Editor's Page, Continued from page 1

System cost—Because of the current popularity of the IBM PC, S-100 systems are available used with 64K and dual eight inch drives for about \$1,000 in the Computer Shopper, and used terminals are about \$300.

We decided that, for our purposes, the S-100 system was the way to go. It may not be the best system for the business user who just wants to run packaged software, but it is ideal for development work in robotics, measurement, and control. We lucked into a great buy on a Morrow Decision I system (this is NOT the MICRO DECISION) with a 14 slot S-100 mother board and a quad disk controller that can handle up to four 5¼ and four eight inch drives in any combination of single or double sided and single or double density at the same time for a total of up to eight drives on line at one time. We can also add a hard disk if we feel the need.

We agree that this is not the best choice for everyone, and we intend to use Sinclair 1000 or Vic-20 systems for dedicated controllers; but we do feel that this was the best choice for our intended purpose. We invite comment, and encourage you to write a rebuttal if you disagree with our choice.

Art Carlson

Classified

Rate: \$.50 per word, minimum charge 7.50. All classified ads must be paid in advance, and will be published in the next available issue. No checking copies or proofs are supplied.

Apple] Data Converter (ADC,DAC). \$149 kit, \$199 assembled. NALAN Computer Specialties, Dept. H, 106 Highland Park Lane, Boone, NC 28607.

For Sale—Soroc IQ120 Terminal \$350; Centronics 797 dot matrix printer, 132 character, parallel input, with manuals \$200; both for \$500. John Kellenberger, Box 1157, Kalispell, MT 59901, 406-755-0923.

Wanted—Documentation for old obsolete computer systems for our reference file. We cannot afford to pay for this outdated material which we may never use, but clean out your basement and send it by the cheapest way. We'll pay the shipping and trade some copies of *The Computer Journal*.

For Sale: SSM 10/4 board for S-100 bus. Two serial, two parallel ports. \$100. DEC LSI-11 minicomputer. Rack mount. KD11-F processor with KEV11 hardware math chip. DLV11 serial card. DRV11 parallel card. Total of 48 K RAM. Paper tape O.S. \$995. Write Lance Rose, c/o *The Computer Journal*, Box 1697, Kalispell, MT 59903.

GEMINI—10X;

Modifications to Allow Both Serial and Parallel Operation

by Bill Kibler

Recent sale prices of the Gemini-10X® printer from STAR micronics make this unit quite attractive for those on a tight budget, and the printer operation is acceptable for a dot matrix printer. The unit comes with a Centronics® parallel interface and several options which can be selected from a DIP switch on the rear of the unit. My current needs are for a parallel interface 90% of the time and a serial interface only about 10% of the time.

STAR manufacturers a serial interface board which fits into a socket on the main printed circuit board and provides an RS-232 socket through the back of the case. This adapter card contains the 1488489 RS232 drivers with patches for DTE/DCE changes, a positive and negative 12 volt regulator, and an LS04 inverter. Interconnection is through a ribbon cable that connects to the adapter card and through the jumper that feeds the parallel input. The Centronics jumper must be removed for serial operation.

Changing between serial and parallel operation is rather time consuming and tedious, as the entire case must be taken apart and cables inserted and removed. The cables are of good quality and would last through several removals and insertions before the contact surface would be affected by wear. However, if the change-over is to be done frequently, this operation would not be satisfactory for two reasons: 1) the cables would eventually fail because of the wear, 2) the switches are located inside of the case and the case would have to be removed each time in order to change them. The solution is to make the serial to parallel switch possible without opening the unit. This improvement can be accomplished by using jumpers and a "serial speed board plug" for the Centronics connection.

Jumpers

The Gemini-10X uses a NEC upd7800 series device, which provides both series and parallel interfaces. In series mode the parallel signal controls most of the attributes. The device has a separate input for serial in/out and a status input to indicate serial operation. The Gemini interfaces the serial adapter through the parallel jumper socket CN3. This connects the baud rate switches to the parallel inputs, grounds the serial status signal, and supplies the serial in/outs to the 7800. If the necessary signals could be changed from the parallel input, only the serial handshakes would be needed in addition to the present wiring. Ten jumpers are required to do this and will require removal of the main PC board.

Take care when removing the plugs that connect the board and printer mechanisms. Mark the connectors and pin positions with masking tape for later reinsertion. Mount the

serial adapter unit in socket CN9. Heat up the iron and get started. Make the following jumpers:

- 1) 8 of CN2 (PC) to 15 of CN1 (Centronics)
- 2) 9 of CN3 (PC) to 9 of CN2 (Adapter)
- 3) 10 of CN3 (PC) to 10 of CN2 (Adapter)
- 4) 11 of CN3 (PC) to 11 of CN2 (Adapter)
- 5) 12 of CN3 (PC) to 12 of CN2 (Adapter)
- 6) 25 of CN3 (PC) to 25 of CN2 (Adapter)
- 7) 27 of CN3 (PC) to 27 of CN2 (Adapter)
- 8) 22 of CN3 (PC) to 22 of CN2 (Adapter)
- 9) 28 of CN2 (Adapter) to 35 of CN1 (PC)
- 10) 29 & 30 of CN2 (Adapter)
to 29 & 30 of CN3 (PC's + 5V)

This will connect the necessary serial signals to the CPU and with the Centronics jumper inserted, the Centronics input will tell it what mode to run. Take care to note that the socket terms CN2 and CN3 are used both on the main and the adapter PC boards. Consulting the adapter manual will illustrate this problem.

Plug

Using a solderable type of Centronics connector, glue a small piece of perf board between the connector pins. Glue an eight position DIP switch to the board. Solder all of one side of the DIP switch together and hook that to pin 19. Connect the following jumpers as follows:

- 1) pin 2 to position 1
- 2) pin 3 to position 2
- 3) pin 4 to position 3
- 4) pin 5 to position 4
- 5) pin 6 to position 5
- 6) pin 7 to position 6
- 7) pin 8 to position 7
- 8) pin 9 to position 8
- 9) pin 1 to pin 11 (stb in/out)
- 10) pin 35 to pin 36 (select in)
- 11) pin 15 to pin 16 (serial signal)
- 12) pin 15 to 19 or common side of switch

This completes the modifications. Now reassemble the unit and test. The Centronics input should work as before. If not, recheck the jumpers (make sure the Centronics jumper at CN3 is back in place). Insert the plug in the Centronics socket and a serial input in the RS-232 plug and test. The switch position will control the baud rate, word length, and parity as documented in the manual. *Continued on page 17*

Multi-user, continued from page 11

terminal. A two-user Horizon goes for about \$5000 without printer or terminal. After this, users are added for around \$500 each (the price of a single board computer), yielding a total price of \$6000 for a four-user system. Adding the necessary four terminals, a printer or so and the necessary wiring brings the total price of a four-user system up to about \$10,000.

You might have noticed that we quoted the price of a two user Horizon at nearly twice the price of a single user system. If the only difference is the addition of another \$500 user CPU this would not make much sense. Actually, a two user system (the minimum configuration of the multi-user version) does possess some other qualities that we haven't mentioned. There is, for example, a third single board CPU which "manages" the shared use of the disk system and common printer(s), as well as the Turbo-DOS software that makes it all possible. The rest of the hardware is essentially the same old Horizon that we remember from five or six years ago. As a matter of fact, you can use an old Horizon for this purpose without modification, just by adding the new boards and software.

Up to a total of eight users can be served with this method; after obtaining the basic package you just add another single-board computer and terminal each time you want to include another user. I would imagine, though, that with more than four users you might want to have another printer somewhere in the system. Each CPU board has two serial ports, so each user could conceivably have a dedicated printer as well as a terminal.

As with multi-user systems of almost any kind, the Turbo-DOS/Horizon combination depends on a common, centrally located disk system. If you go for more than a very few users you might also want more disk space than the bare-bones model can offer. The disk system is located in the central Horizon cabinet, which also contains all of the other boards that make up the system. We should add that the hard disk is a relatively inexpensive Horizon option that simply replaces one of the floppys.

North Star's multi-processor can accomodate up to eight users at a cost considerably less than an equal number of separate micros and with much more operating power per user than a timesharing system of this size and price range. The "single-boards" are available in both 8-bit and 16-bit models, which can be mixed in the system. The 16-bit job, though, takes two slots per user because of extra memory requirements, so you can only have four of them. Or you could conceivably have two 16-biters and four 8-biters in the same box, or some similar combination utilizing up to all eight of the available expansion slots.

Another very similar product is turned out by Action Computer Enterprise (Pasadena CA) in the form of their Discovery[®] System. As with the Horizon, this is an S-100 bus into which many cards can be plugged. Some of them can be single board computers similar to those we described earlier. The basic box can be configured as either a single microcomputer, several functionally separate microcomputers, or what they call a DPC-Net[®]. The

software that makes this possible is essentially a CP/M spin-off known as dpc-os[®].

As a multi-processor, the DPC can handle up to 15 users, who share peripherals. This operating system, in addition, permits timesharing of each of the 15 single board computers that reside in the central box. Theoretically, then, up to 150 users can be accomodated but 15 is a more reasonable claim. Although the Discovery is advertised as a net, it is really in the MU/MP class.

Compu-Pro has also recently announced a multi-processor system which (so far) is being promoted as a four user system.

One of the multi-processor disadvantages is that the terminals have to be reasonably close to the "box." In order to avoid networking's expensive communication techniques, the terminals are driven by fairly ordinary I/O (input/output) ports, such as the RS-232 type. If RS-232 is used you can only expect to run the terminals about 50 feet from the computer. Slightly more sophisticated ports (for example, some version of RS-449) offer a trade-off between speed and distance and give you a reasonable speed at up to several hundred feet.

There are places for all of these different multi-user computer systems: timesharing, multi-processors and networks. Schools, labs and small businesses are all prime candidates; knowing the differences between systems, and their individual limitations, could help you make the right choice. In our next multi-user column we'll introduce the concept of true networks (LANs) and describe in more detail how some of the more successful and popular ones perform. ■

Horizon[®] is a registered trademark of North Star Computers, Inc. CP/M[®] is a registered Trademark of Digital Research. Discovery[®], DPC-Net[®], and dpc-os[®] are all registered trademarks of Action Computer Enterprise.

Gemini 10x, continued from page 16

These modifications will allow the unit to work in the stock parallel mode, or in the serial mode with the plug inserted in the Centronics socket. The jumpers are designed to work with the manufacturer's serial interface. It is possible to use the Centronics input and build your own serial converter for less money. This article, however was written for those like myself who purchased the adapter and then discovered its limitations. ■

Books of Interest

Real Time Programming — Neglected Topics

by Caxton C. Foster

Published by Addison-Wesley Publishing Co.

Jacob Way

Reading, MA 01867

190 pages, 9 1/4 x 5 3/4, \$9.95

This is a very interesting and helpful book, and it is written in a down-to-earth manner. A good example of the flavor of the book is the preface which starts "This book is about some of the problems you will run up against if you try to connect a digital computer to the real world. It is more a survey of these problems than it is a collection of cookbook recipes for solution of the problems. By the time you finish reading this book and doing the experiments described herein, you will begin to have an appreciation of all the things you don't know and we didn't know how to tell you." Another choice comment is in the section on filters where Foster discusses other books on the subject and says "Most of the authors lost touch with the real world so long ago they have forgotten which direction it is in." In this book Foster writes for the advanced hobbyist who is interested in information which he can use rather than a Doctoral thesis to impress other academicians.

The contents are as follows:

- Chapter 1 BASIC INTERRUPTS. Polling, Single Interrupts, Edge versus Level, Clearing an Interrupt, Debouncing a Switch, A Clearable Interrupt, and Two Interrupts.
- Chapter 2 PORTS. Reaching the Device, Recognizing Your Name, Input Output Port, One-Shot Timer, Serial Ports, Peripheral Interface Adapters-PIAs, and PIA Interrupt Lines.
- Chapter 3 MULTIPLE INTERRUPTS. Nesting Interrupts, Masking Interrupts, Hierarchical Interrupts, and Vectored Interrupts.
- Chapter 4 MATCHING UP SPEEDS. Semaphores, Handshaking, Keyboard, Printer, and IEEE-488 Bus.
- Chapter 5 ECHO AND REVERBERATION. Echo, Limited but Quick Multiplications, Output-Digital to Analog Conversion, and Analog to Digital Conversion.
- Chapter 6 THE SAMPLING THEOREM. Stroboscopic Stop Action, Another Way to Look at It, Sampling a Sine Wave, and Nonsinusoidal Inputs.
- Chapter 7 FILTERS, DIGITAL AND OTHERWISE. A Low-Pass Filter, Double Filtering, High-Pass Filters, Band-Pass Filters, and Impulse Response.
- Chapter 8 CLOSING THE LOOP. Defining

Some Terms, Analysis of a Simple Servomechanism, and A Second-Order Servo.

- Chapter 9 FANCIER CONTROLS. Derivative Feedback, Error-Rate Control, Integral Control, and Bang-Bang Control.
- Chapter 10 OPTIMUM AND ADAPTIVE CONTROL. The Phase Plane, Eight Types of Behavior, Bang-Bang Servo Revisited, Optimum Control, Adaptive Control, and Sophisticated Adaptation.
- Chapter 11 THE LUNAR LANDER. Servo Motor, Stepping Motor, Rockets, Direct Measurement of Position, Velocity Measurement, Equations of Motion, and Interface with the Pilot.
- Chapter 12 COMMUNICATION OVER RESTRICTED PATHWAYS. Single-Channel Control, Multiplexing, Frequency Multiplexing, Time-Division Multiplexing, Space-Division Multiplexing, The Organization of Buses, Multibus, Ring Networks, Star Networks, Common Bus, The Music Master, Folding the Conductor, Sharing Ports, and Direct Memory Access.
- APPENDIX. A Description of Our Hypothetical Machine.

The entire book is so interesting that it is hard to pick out a section to talk about. If you need good, solid, basic information on interrupts, ports, and the other subjects listed in the contents, this book is highly recommended. My copy is going to be kept chained to the desk because I know that I'll be referring to it often. ■

Art Carlson

Basic Robotic Concepts

by John M. Holland

Published by Howard W. Sams & Co., Inc.

4300 West 62nd St.

Indianapolis, IN 46268

270 pages, 5 3/8 x 8 1/2 softbound. \$19.95

The contents are as follows:

- INTRODUCTION. A short History, Enter the Japanese, and The Future.
- Chapter 1 MOTORS AND METHODS. Types of Systems, Electrical Motors, Tachometers and Position Encoders, Servomotor Control Techniques, Hydraulic Motors and Controls, Air motors, and Gears and Linkage.
- Chapter 2 MANIPULATORS. Types of

Manipulators, Defining the Various Joint Motions of a Robot, Position Control, Motion Transformation and Coordination, Coordinated Movement, Matrices and Jacobian Transformers, Force Sensing and Compliance, Grippers and Touch, Programming the Robot Arm, and Special-Purpose Manipulators.

•Chapter 3 MOBILITY. Disadvantages of Fixed Robots, Mobile Robots in Manufacturing, Other Applications for Mobile Robots, Designing the Carriage System, The Importance of Stability, Driving the Wheeled Carriage, and Advanced Carriage Systems.

•Chapter 4 PASSIVE VISION SYSTEMS. The Vidicon Camera, Plumbicons and Other Relatives of the Vidicon, Composite Video, Charge Coupled Devices (CCDs), Other Solid State Camera Technology, Optical Considerations, Digitizers and Preprocessors, Full-Frame Image Processing, Two-Dimensional Processing, Recognizing the Closed-Edge Image, Area, Moments, and the Axis of Minimum Inertia, The SRI Algorithm and Moment Invariants, Color Vision, Three Dimensional Video Processing and Range Determination, Structured Light Vision Systems, and The Vision System as an Integrated Part of the Robot.

• Appendix A MATHEMATICAL EQUATIONS. Motor Equations for Chapter 1, Gear and Actuator Equations, Torque Conversion Table, Rotary Inertia Conversion Table, Mobility Equations for Chapter 3, and Equations for Chapter 4.

• Appendix B SAMPLE PROGRAMS. Program CG.BAS for Determining the Center of Gravity, Sample Run of Program CG.BAS, Program STABLE.BAS for Determining the Limits of Stability, and Sample Run of STABLE.BAS.

Basic Robotic Concepts, which is a part of the BLACKSBURG series, covers the fundamental aspects of robotics. It by no means tells you everything that you need to know about robotics; but it does contain some much needed, but frequently overlooked, information which is necessary for the person seriously interested in robotics.

The book is well written, is easy to understand, and shows the results of considerable thought and effort to present technical information in an easy to follow manner. A good example of the care taken with this book is the inclusion of 27 pages of mathematical equations in the appendix where they are available to those who need them, without breaking up the flow of the text in the main part of the book. It is also much more convenient to have the equations gathered in one place for easy reference instead of having to search through the book for them.

The sections on motors, manipulators, and mobility are all good, but the extensive treatment of mechanical stability where Holland covers center of gravity, static stability, dynamic stability, and dynamic turning forces, is especially

important. I have seen little mention elsewhere of this critical aspect of mobile robots.

Holland is an independent consultant specializing in industrial control systems, and obviously is very familiar with the subjects covered in this book.

I find that a very high percentage of the books which interest me are being published by Sams. Am I missing offerings by other publishers, or are the publishers missing the market? Feedback from our readers on which books they find most useful will be greatly appreciated.

Art Carlson

Apple II Applications

by Marvin L. De Jong

Published by Howard W. Sams & Co. Inc.

4300 West 62nd St.

Indianapolis, IN 46268

236 pages, 5 3/8 x 8 1/2, softbound, \$13.95

In his new book, *Apple II Applications*, De Jong shows how to use the Apple to make measurements of physical quantities, to control other devices, and to communicate with other computers. It is written in his usual easy to read style with many useful examples combining simple software and hardware techniques into practical projects.

The contents are as follows:

•Chapter 1 APPLICATIONS USING SERIAL I/O. Review of Input/Output Fundamentals, Asynchronous Serial I/O, the RS-232C Interface Standard and the ACSII Code, More on Modems, Serial I/O with a Modem, Transferring Information From One Computer to Another, and Telecomputing.

•Chapter 2 GAME I/O CONNECTOR APPLICATIONS. The Flag Inputs, Annunciator Outputs, The Game-Control Inputs, a Solar Tracker, and Some Hardware Considerations.

•Chapter 3 PROGRAMMING YOUR OWN EPROMS. ROM, PROM, EPROM, and EEPROM, the 2716 EPROM, Programming the 2716 EPROM, Erasing the 2716 EPROM, and Using the 2716 EPROM.

•Chapter 4 DIGITAL-TO-ANALOG CONVERSION. Operating a D/A Converter, a Function Generator, and Other Applications.

•Chapter 5 ANALOG-TO-DIGITAL CONVERSION. Operating the A/D Converters, Testing the A/D Converters, A/D Data-Logging Techniques, and Making Measurements With an A/D Converter.

•Chapter 6 TIMING AND COUNTING. Timing and Counting With the 5622 VIA, Pulse Counting, Precision Timing, Logging Times, and Using the Mountain Computer Clock Board.

Some of the interesting applications presented in this book are camera shutter speed testing, constant temperature bath, proportional control of an AC load, switching

Continued on page 22

New Products

North Star Announces DIMENSION

North Star Computers, Inc. has announced the first IBM PC/XT compatible microcomputer system for multiple users, the North Star DIMENSION.

The DIMENSION is a multi-processor, multi-user system that can support up to 12 workstations, each running a different IBM PC/XT business application. The heart of the system is a high performance, single-board computer based on the Intel 80186 processor, and a 13-slot IBM bus. Each user has a dedicated workstation processor board that connects to the IBM bus. The CPU for the workstation board is an 8088-2, which is a faster version of the CPU in the IBM PC/XT. The DIMENSION's operating system is compatible with IBM PC-DOS 2.0 and has built-in electronic mail capability for up to 12 users. It provides each user with the equivalent of an IBM XT with networking and shared access to expensive resources such as fixed disks, printers and communications devices. The cluster of up to 12 users is connected through the IBM bus, providing an extremely fast communication link. Among the options for the system are sophisticated communications links to mainframe computers such as a 3270 cluster controller.

Standard equipment on the new product includes one 360 kilobyte floppy disk drive, one 15 megabyte or 30 megabyte fixed disk, and add-in spaces for a second fixed disk and an integrated tape back-up system. The 186 main processor board comes with 256 kilobytes of RAM, which can be expanded to half a megabyte. This RAM is primarily used as cache memory to provide high-speed interaction between users and the hard disk. Each workstation board includes 128 kilobytes of RAM, which is also expandable to half a megabyte. Workstations also come with a local RS-232 interface to connect a local printer or mouse device.

The primary benefit of the DIMENSION's architecture is the higher performance available at a significantly lower per-user cost than multiple single-user systems. For a five-user configuration with equivalent hard disk storage, the DIMENSION is as much as 50% less expensive per workstation than five IBM PC/XTs and 30% less per user than five single-user IBM clones. The DIMENSION's multi-processor design assures that there is no loss of computing power as users are added to the system.

In addition to the benefits inherent in a multi-user system, the North Star DIMENSION offers IBM PC/XT compatibility. The system can run popular IBM PC/XT business applications, and the 13-slot IBM bus can utilize most add-in hardware for the IBM with minor modifications. Keyboard overlays for the PC and XT can be transferred directly to the DIMENSION workstation keyboard. North Star has also made enhancements to the basic IBM system

such as simultaneous display of graphics and character mode, which eliminates the "hash" frequently visible on IBM PC/XT displays.

The list price for the North Star DIMENSION is \$7,000 for a complete system with a 15 megabyte hard disk. This price includes two workstations, a floppy disk and the operating system. A 30 megabyte version of the same configuration lists for \$8,000. Each additional workstation is \$1,500. The product will be available in the first quarter of 1984. North Star also will release IBM host communications capability and a streamer tape back-up with 45 megabyte capacity. ■

New Accessories for the ADALAB Card

Interactive Microware, Inc. (IMI) now offers five new accessories for its ADALAB[®] data acquisition and control interface card. The ADALAB card, which is designed for use with the Apple[[+ microcomputer, controls and collects data from most scientific instruments, including chromatography systems, spectrophotometers, pH meters, strip chart recorders, temperature controllers, etc.

New IMI accessories include: ADA-AMP—an instrumentation amplifier with 0.1 to 1000 gain range; VIDISAMPLER—a real-time data acquisition software option that permits simultaneous data acquisition from four analog inputs; VIDIMEMORY—an extended memory/bulk data storage software option that works with 16, 64, and/or 128K RAM cards offered by IMI; TEMPSENSE—a hardware/software package for temperature monitoring (up to 64 thermocouples or heat sensors may be monitored); and ADA-BYTE—a 32 bit digital I/O multiplexer accessory.

For further information, write Interactive Microware, P.O. Box 771, State College, PA 16801 or call IMI General Manager John Kalasky at (814) 238-8294. ■

A Prototype Development Board for IBM PC

Real Time Devices has announced the Prototype Development Board (PD100) for the IBM Personal Computer, which provides the means to quickly interface prototype circuitry.

A unique feature of the PD100 is a switch selectable address decoder which frees the experimenter to concentrate on his design. Additionally, four I/O device select input and output signals, four power supply voltages and a buffered data bus are available at wire wrap posts. A rocker switch allows the selection of up to four unique addresses that do not contend with present IBM peripherals. This permits up to four boards to be utilized in

continued on page 22

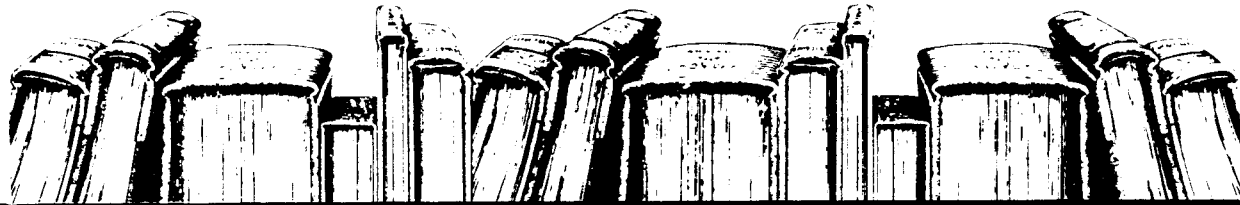

The Bookshelf

CP/M Primer

Helps microcomputer veterans and novices alike find the answers about CP/M in a complete, one-stop sourcebook that's a Sams best-seller! Gives you complete CP/M terminology, hardware and software concepts, startup details, and more for this popular 8080/8085/2-80 operating system. Helps you begin using and working with CP/M immediately, and includes a list of compatible software, too. By Stephen Murtha and Mitchell Waite. 96 pages, 8 1/2 x 11, comb. © 1980. \$14.95

Soul of CP/M: Using and Modifying CP/M's Internal Features

Teaches you how to modify BIOS, use CP/M system calls in your own programs, and more! Excellent for those who have read *CP/M Primer* or who otherwise understand CP/M's outer-layer utilities. By Mitchell Waite. Approximately 160 pages, 8 1/2 x 9 1/2, comb. © 1983. \$14.95

The S-100 and Other Micro Buses (2nd Edition)

Examines microcomputer bus systems in general and 21 of the most popular systems in particular, including the S-100. Helps you expand your computer system through a better understanding of what each bus includes and how you can interface one bus with another. By Elmer C. Poe and James C. Goodwin, II. 206 pages, 5 1/2 x 8 1/2, soft. © 1981. \$9.95

Interfacing & Scientific Data Communications Experiments

Introduces you to the principles involved in transferring data using the asynchronous serial data-transfer technique. Focuses on using the universal asynchronous receiver transmitter (UART) chip in order to help your understanding of communication chips. Explores operation of teletype-writer interfaces and serial transmission circuits. With experiments and circuit details. By Peter R. Rony. 160 pages, 5 1/2 x 8 1/2, soft. © 1979. \$7.95

Active-Filter Cookbook

A practical discussion of the many active-filter types and uses, written by one of Sams' most popular authors. Teaches you how to construct filters of all types, including high pass, low-pass, and bandpass having Bessel, Chebyshev, or Butterworth response. Easy to understand—no advanced math or obscure theory. Can also be used as a reference book for analysis and synthesis techniques for active-filter specialists. By Don Lancaster. 240 pages, 5 1/2 x 8 1/2, soft. © 1975. \$14.95

IC Converter Cookbook

Discusses and explains data conversion fundamentals, hardware, and peripherals. A valuable guide to help you understand and use d/a and a/d converter applications. Includes manufacturers' data sheets. By Walter G. Jung. 576 pages, 5 1/2 x 8 1/2, soft. © 1978. \$14.95

IC Timer Cookbook

Gives you a look at the hundreds of ways IC timers are used in electronics. Provides a collection of numerous recipes for using the IC timer, including a 555 monostable circuit with auxiliary output, a touch switch, a programmable monostable circuit, and hundreds of others. By Walter G. Jung. 288 pages, 5 1/2 x 8 1/2, soft. © 1977. \$10.95

IC Op-Amp Cookbook

An informal, easy-to-read guide covering basic op amp theory in detail, with 200 practical, illustrated circuit applications to reflect the most recent technology. JFET and MOSFET units are shown in both single and multiple formats. Includes manufacturers' data sheets, and lists addresses of the companies whose products are featured. By Walter G. Jung. 480 pages, 5 1/2 x 8 1/2, soft. © 1980. \$15.95

Regulated Power Supplies (3rd Edition)

Newest, most comprehensive discussion you'll find of regulated power supplies, including their internal architecture and operation. Thoroughly explains how to use regulation in your designs and projects when the need arises, and discusses practical circuitry and components. A valuable book for any technician or engineer involved in servicing or design. By Irving M. Gottlieb. 424 pages, 5 1/2 x 8 1/2, soft. © 1981. \$19.95

TTL Cookbook

Popular Sams author Dan Lancaster gives you a complete look at TTL logic circuits, the most inexpensive, most widely applicable form of electronic logic. In no-nonsense language, he spells out just what TTL is, how it works, and how you can use it. Many practical TTL applications are examined, including digital counters, electronic stopwatches, digital voltmeters, and digital tachometers. By Don Lancaster. 336 pages, 5 1/2 x 8 1/2, soft. © 1974. \$11.95

SCRs and Related Thyristor Devices

A comprehensive guidebook to the operational theory and practical applications for silicon controlled rectifiers, triacs, diacs, unijunction transistors, and other members of the thyristor family. Also contains a microprocessor mini-course to help you in interfacing thyristors with digital control circuits. If you're involved with design, installation, or maintenance of electronic power-control equipment, this is the book for you. By Clay Laster. 136 pages, 8 1/2 x 11 1/2, soft. © 1981. \$12.95

Instrumentation: Transducers, Experimentation, and Applications

A laboratory-oriented manual that helps provide you with an in-depth understanding of instrumentation and measurement. By Roger W. Prewitt and Stephen W. Fardo. 224 pages, 8 1/2 x 11, soft. © 1979. \$12.95

The Computer Journal

PO Box 1697 Kalispell, MT 59903

Order Date _____

Print Name _____

Address _____

City _____ State _____ Zip _____

Check Mastercard Visa

Card No. _____ Expires _____

Signature for Charge _____

Qty	Title	Price	Total
Shipping charges are: \$1.00 for the first book, and \$.50 for all subsequent books. Please allow 4 weeks for delivery.		Book Total	
		Shipping	
		TOTAL	

Letters From Our Readers

Dear Computer Journal,

Enjoyed your first issue very much. Too bad you changed the name, it felt like a special club. But the content is the important thing and I find the content exactly right.

How about some information on interfacing 8 inch drives to C-64?

M.M.

Oregon

Dear Computer Journal,

I have just finished perusing the premier issue of your magazine (on loan from a friend).

I like the things you have to say about the lack (of late) of information and articles for the computer enthusiast who wants to experiment with the capabilities of his/her computer. Your article "Anyone For a Little KISS Electronics?" hit especially close to home. I've been a great one of the "keep it, you'll never know when it will come in handy" people, but there is a limit to the amount of "junk" I can ship around the world with me.

I would like to see articles concerning programming techniques, the kind that show you all those neat memory saving ways to do things. I'm one of a number of people who have a TRS-80 or TRS-80 compatible system with 48K of user RAM and a couple of disk drives. To do the kind of programming I want to do (or do do) usually eats up most of my available memory. Until I can find a better way, I usually program in sections, renumber the many sections, then merge them together and pray it not only fits but works.

Other than 80 column word processing, there seem to be few uses for hires on the LNW-80 Model I (of which I am the proud builder/owner). I am really determined to program something (games, educational, etc.) that will have full use of the LNW-80's hires capability, but right now it seems as if I will have to muddle through because no one out there is doing any articles on the subject.

I promise you that when I have a program that does what I am hoping to do I will not only let you evaluate it for publication (I hope it proves out to be that good), but will include an article or something explaining the techniques I worked out to handle it.

Keep up the good work with your magazine. I hope that hackers everywhere discover it and subscribe.

Sincerely yours,

R.S.

Illinois

Dear Computer Journal,

I am a new subscriber to your journal, and whether the "Hacker" terminology is used or not, what I've seen so far makes me want the first two issues, if they are available. I

especially want No. 2, since it includes the first part of the print spooler. Many thanks, and may your future be filled with good, growth, and more articles of the same type as are contained in Vol. 1, No. 3.

D.H.

New York

Dear Computer Journal,

I am currently interested in modifying and adding to a TRS-80 MC-10.

I want to add a LCD in the case and modify the selectric adapter (in *Radio Electronics* December '83 and following) to fit. I am considering replacing the 2650 microprocessor used with a MC6802CP.

I am a student at Edison State College in Electronics and electro-mechanical tech. I need three more courses for the degree and I think this is a good project. I need info on the MC-10.

Thank you,

A.W.S.

Ohio

Books of interest, continued from page 19

at the zero crossing of an AC voltage, measuring light intensity, measuring temperature, a solar tracker, reading and programming EPROMs, A/D and D/A, and timing and counting.

Too many books are so over simplified that they don't tell you anything useful, or so esoteric that they are difficult to understand unless you already know the subject. This book contains useful information presented at a down-to-earth level, and should be very helpful to anyone wanting to connect their Apple to things in the real world.

This book is available from Group Technology, Ltd., P.O. Box 87, Check, VA 24072, for \$13.95 plus \$1.00 shipping ■

New Products, continued from page 20

one PC system.

Two areas are available for circuit prototype; one is situated for installation of I/O connectors. These prototype areas are comprised of a grid of over 1600 pads on 0.1 inch centers suitable for soldering and installation of up to 40 wire-wrap sockets.

A comprehensive 116-page documentation and projects manual is provided with each PD100 board. This manual includes detailed circuits of I/O ports, A/D, D/A converters, transducers, and other useful interfaces along with BASIC application programs that illustrate control of the devices.

Contact Patricia Szybist, Sales Coordinator, Real Time Devices, PO Box 906, State College, PA 16801, (814) 234-8087. ■

MICROCOMPUTER USER'S SURVEY

None of us like to fill out forms, but *The Computer Journal* needs to know what you are doing in order to serve you better. We would appreciate your answers to the following questions. If only certain questions interest you, answer those and leave the rest blank. Feel free to copy this form and pass it around to your associates and friends, we value their feedback too!

HARDWARE: What microcomputer system(s) do you use regularly? IBMpc, TRS, Apple, Morrow, North Star, Osborne, other: _____
Model and memory size _____

OPERATING SYSTEM: What operating system(s) do you use? CP/M80, CP/M86, MS-DOS, PC-DOS, TurboDOS, Applesoft, Apple CP/m, CP/M68K, CCP/M86, MP, TRS-DOS, UCSDp system, Unix, other: _____

LANGUAGES: Which languages do you use regularly? Basic, Pascal, Fortran, FORTH, Assembly, CBasic, C, Lisp, APC, ADA, PILOT, Cobol, RPG, PL, other: _____
Which languages would you like to learn? _____

I/O PORTS: What input and output ports do you have on your system? _____

STORAGE: What off-line storage do you use? Disk, tape, punched tape, other: _____
Format (disk size, density, number of sides, etc.) _____

INTERESTS:

Would you rather:

- Design and build your own hardware?
- Build a project from complete step-by-step instructions?
- Assemble a kit?
- Buy completed peripherals and just plug them in?

Are you interested in:

- Writing technical applications programs?
- Writing assemblers or compilers for new CPU's (such as the 68000)?
- Learning to write assembly language programs for new CPU's?
- Exchanging scientific and technical software?

At what level would you rate your experience (High, Medium, or Low):

Programming? _____
Hardware construction? _____
Electronics? _____
Interfacing? _____

What would you like to learn about your computer (what types of articles should we publish)?

- Interfacing, assembly language, measurement, control, optoelectronics, robotics,
- stepper motors, hardware construction, electronics, A/D & D/A, programming

continued

If you could choose the topics for the articles in the next issue, what would they be?

- 1) _____
- 2) _____
- 3) _____
- 4) _____
- 5) _____
- 6) _____

Thank you for your time, thoughts, and additional comments.

PLACE
STAMP
HERE

The Computer Journal
P.O. Box 1697
Kalispell, Montana
59903